

Operator's Manual

MODEL WSP-L240

(2inch Mobile Printer)

Rev. 1.0



All specifications are subjected to change without notice

■ Copyright

WSP-L240 Low Voltage 2inch mobile printer operator's manual.

Copyright ©2020 by Woosim Systems Inc.

All rights reserved.

The information contained in this manual is the property of Woosim Systems Inc.

And may not be reproduced in whole or in part without the prior written permission of Woosim Systems Inc.

■ Trademark



a registered trademark of Woosim Systems Inc.

All other trademark are the properties of their respective companies.

■ Caution

Some semiconductor devices are easily damaged by static electricity. You should turn the printer "OFF", before you connect or removed the cable on the rear side, in order to guard the printer against the static electricity.

If the printer is damaged by the static electricity, you should turn the printer "OFF"

■ Notice

The contents of this manual are subject to change without notice.

■ Introduction

The **WSP-L240** is the ideal solution for Mobile banking system , Retail, point of sales, Credit card Transaction, other traveling and mobile computing etc.

The general features of **WSP-L240** printer are as follows:

- ▶ Pocket size (80 x 121.3 x 47.4mm)
- ▶ Light weight(224.86g) for true mobility
- ▶ Very silent printing thru direct thermal printing method
- ▶ High resolution(203dpi : 8dots/mm)
- ▶ Print speed (52mm/sec, MAX)
- ▶ USB Charging
- ▶ USB, Bluetooth(Classic and BLE) interface
- ▶ Support Graphic OLED(128×64dots)
- ▶ Support Magnetic Stripe Reader (1&2&3 tracks)
- ▶ Support text and graphic printing
- ▶ Easier paper roll loading by CLAMSHELL design
- ▶ One touch paper cover
- ▶ Printer door open & Paper-out sensor
- ▶ Easier maintenance with self-diagnostic.
- ▶ In field programming – Update Firmware, Download Fonts and Logos
- ▶ Microsoft Windows/Windows CE, Linux, Android, iOS compatible
- ▶ Flow control : Software (XON/XOFF)
 - ※ Hardware flow control not supported in printer.

■ Operating Precautions

Please follow the precautions below to enjoy and maintain the full performance of the printer.

▶ Using the Printer

- Be careful not to drop or bump the printer on a hard surface.
- Do not install the printer in direct sunlight or such areas.
Suitable environment for the use of the printer is as follows:
 - ◆ Operating temperature: -10°C to 50°C
 - ◆ Relative humidity : 30% to 80%
- Do not install the printer near devices that generate strong electromagnetic fields such as a copy machine.
- Do not open the platen cover during printing .
- Do not remove or reinstall the communication cable during printing or transmission.
- Do not touch the connectors of the communication during printing.
- Switch the POWER OFF when not in use.
- Do not use other solvent.
- The battery pack may become warm when in use. This is normal and is not a malfunction.
- When the battery pack is used at low temperature, the length of time the printer can be used may be shortened.

▶ Thermal Paper Handling

- Store the thermal paper in a cool, dry and dark place.
- Do not rub the paper with hard object.
- Do not leave the paper with hard object.
- Do not allow plastic film, erasers, or adhesive tape to touch the paper for long periods.
- Do not stack the thermal paper with diazo copies immediately after copying or wet-type copies.
- Do not use chemical glue.
- Always use the clean thermal paper.

CONTENTS

- 1. Outline.....6**
 - 1.1. Model classifications 6
 - 1.2 Product Part Number System..... 7
 - 1.3. Specifications..... 8
- 2. Setting up the printer..... 9**
 - 2.1. Printer & Accessories 9
 - 2.2. Printer Features 10
 - 2.3. Dimensions..... 11
 - 2.4. Replacing paper roll..... 12
 - 2.5. Power supply..... 13
 - 2.5.1. Specified power supply..... 13
 - 2.5.2. Installing the battery 13
 - 2.5.3. Recharging the battery pack..... 14
 - 2.6. Set operation mode 15
 - 2.7. Memory switch table..... 17
- 3. Interface..... 18**
 - 3.1. USB 18
 - 3.2. Bluetooth 19
 - 3.3. Read a magnetic stripe card..... 19
- 4. Using the printer..... 20**
 - 4.1. Control panel 20
 - 4.2. The self test..... 21
 - 4.3. Using the Belt clip 21
- 5. Consumable Parts..... 22**
 - 5.1. Recommended paper..... 22
 - 5.2. Printing position..... 22
- 6. Revision History 23**

1. Outline.

1.1. Model classifications.

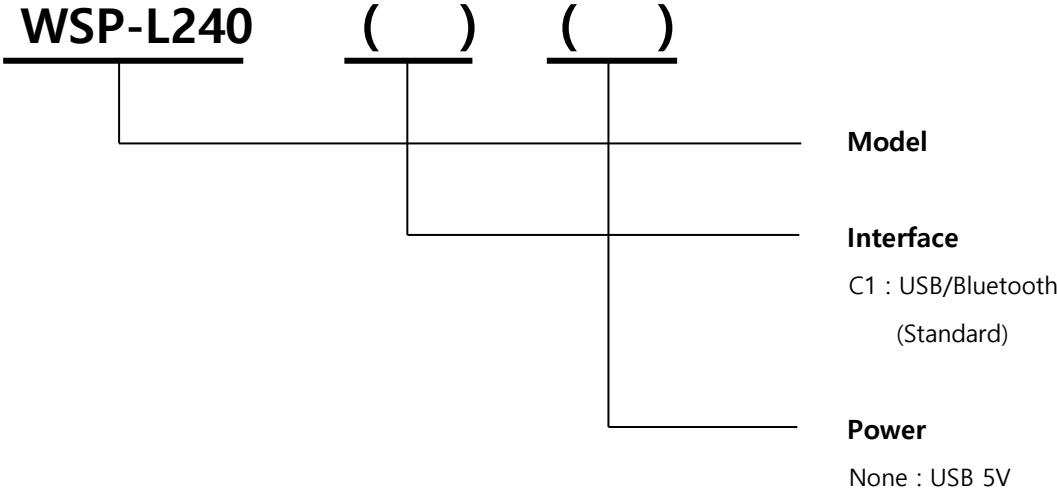

1.2 Product Part Number System

Model name / Interface Spec.

S40 SC30 W25 . . .	Wired A RS-232C B TTL C USB D RS-485 E Parallel Z None	Wireless 1 Bluetooth 2 IrDA 3 Wireless LAN 0 None
-----------------------------------	---	--

Example) 1. Porti-S40 Serial/Bluetooth Part No. ⇒ S40/A1
2. Porti-SC30 Bluetooth Only Part No. ⇒ SC30/Z1

Note) The above table is the interface format which is supported.
But some of the interfaces are not supported according to the product and please contact us, if you have any questions regarding the interface.

1.3. Specifications.

Item	Specifications	
Print method	Direct thermal line printing	
Character size	- Font Size A: 12X24 / Font Size B : 9X24 / Font Size C : 8X16 - KOR : 24X24(16X24) / CHN, JPN : 24X24	
Characters per line	- Font A : 32cpl / Font B : 42cpl / Font C : 48cpl - KOR : 16cpl(24) / CHN, JPN : 16cpl	
Optional Characters	Alphanumeric:95, Extended Graphics:128X50 pages, International:10, Simplified/Traditional Chinese, Japanese, Korean	
Resolution	203dpi, 8dots/mm	
Print width	2-inch (48mm, 384dots)	
Print speed	52mm / sec (MAX)	
Dimension	80 x 121.3 x 47.4mm	
Weight (w/o paper)	224.86g	
Interface	USB, Bluetooth(Classic and BLE)	
Paper roll	Thermal roll paper, Label roll (58mm wide, 40ø)	
Barcodes	1-dimension : UPC-A, UPC-E, EAN-8, EAN-13, CODE-39, CODE-93, CODE-128, ITF, CODABAR 2-dimension : PDF417, Micro PDF417, Truncated PDF417, QR-CODE, DATA Matrix, Maxicode Etc :GS1 databar	
Driver	Microsoft Windows, Linux	
H/W Spec	MCU : RX-32bit, RAM : 128M bit, FLASH : 64M bit	
Receive buffer size	1M bytes	
Sensor	Support Cover open, Paper empty	
OLED	128×64 Dots (Light Blue)	
MSR	Triple tracks (1&2&3 Tracks Reading) *Supports 3DES & AES encryption	
Battery	Rechargeable 3.7V DC, 1800mAh (Li-ion)	
Battery charger	USB 5V Charge / 3hours full charge time (5V, 1A Adaptor use)	
Environment Conditions	Temperature	-10°C ~ 50°C (operating) -10°C ~ 70°C (storage)
	Humidity	30% - 80% (operating) 10% - 90% (storage)
MCBF (Mean Cycle Between Failure)	Head	Approximately 100Km

< Table 1 >

2. Setting up the printer.

2.1. Printer & Accessories

Your printer box should include these items. If any items are damaged or missing, please contact your dealer for assistance.



WSP-L240

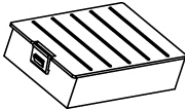

Battery Pack



Thermal roll paper

▼ **OPTIONAL**

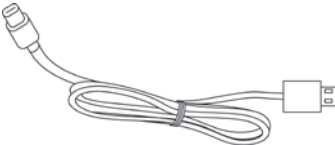

USB cable <Type C>



Belt clip

2.2. Printer Features

► Part Name

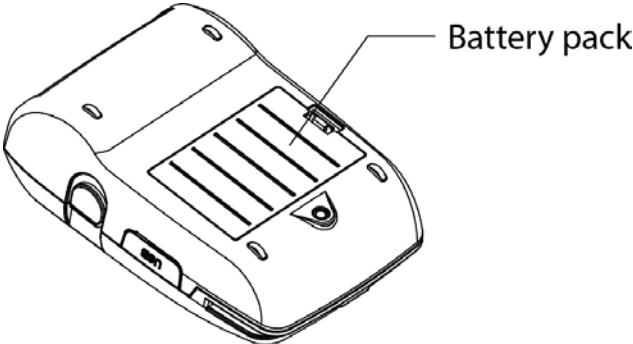
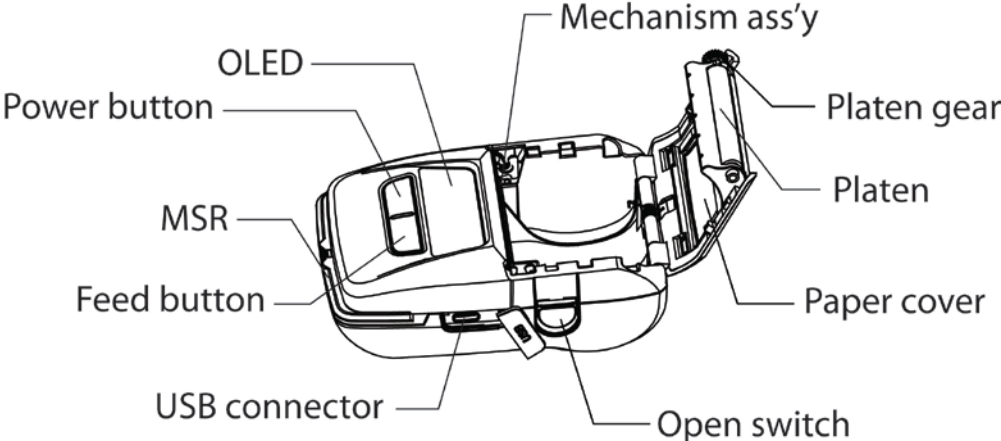

2.3. Dimensions

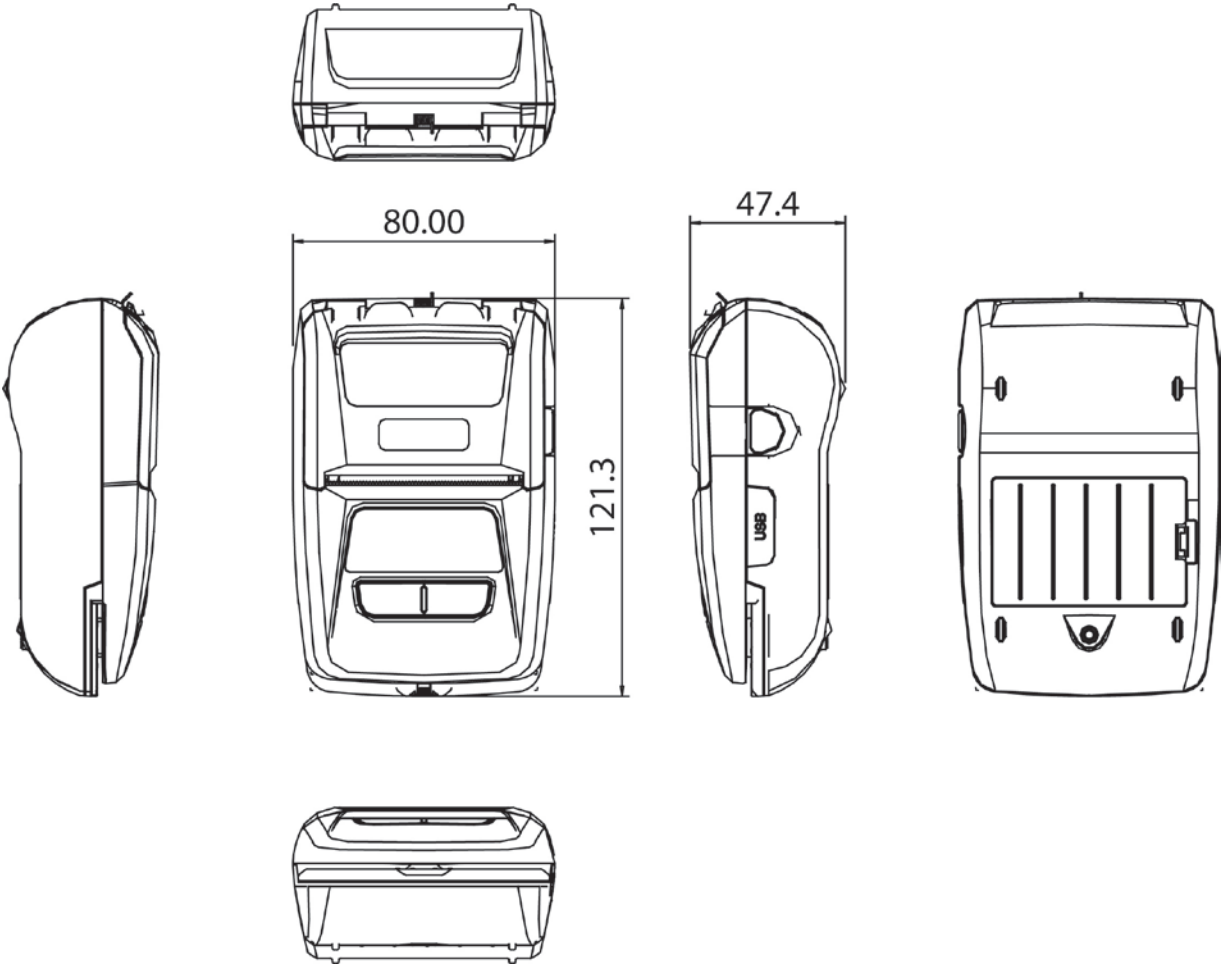

2.4. Replacing paper roll.

Note : Be sure to use paper rolls that meet the specifications.

Do not use paper rolls that have the paper glued to the core because the printer can not detect the paper end correctly.

1. Make sure that the printer is not receiving data; otherwise, data may be lost.
2. Open the paper cover as the "One-Touch" way by pressing the button in the arrow direction like the picture.

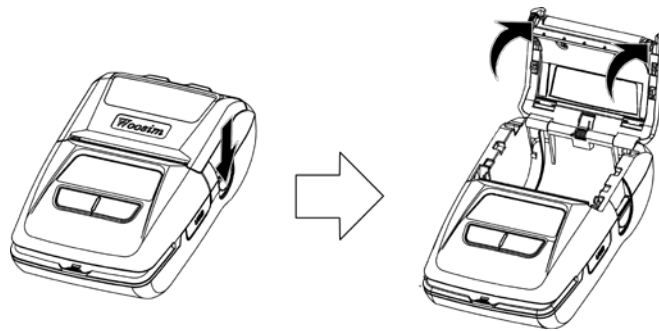

3. Insert a new paper roll as shown.

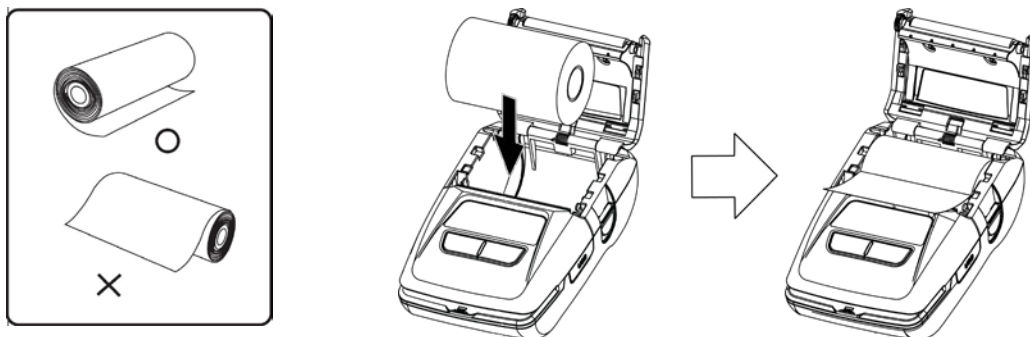

4. Tear the excess paper off using the edge of paper door as a tear bar.

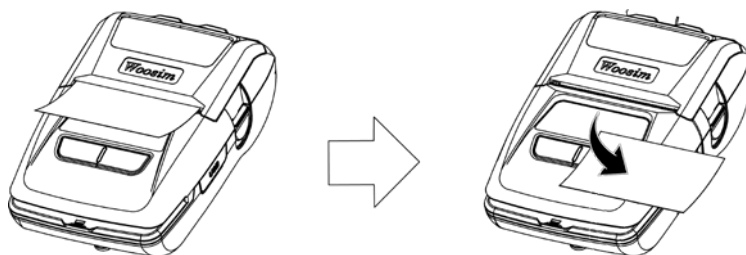

2.5. Power supply

2.5.1. Specified power supply

The following specification is requested for Power supply.

Battery Charger : USB 5V

Avoid using power supply which its power capacity of power current is extremely high.

2.5.2. Installing the battery

Warning :

- Before installing or removing the battery pack, ensure the printer is OFF.
- If the printer is not used for long period of time, remove the battery pack from the printer.
- Risk of explosion if battery is replaced by an incorrect type.
Dispose of used batteries according to the instructions.
- Batteries are provided not being charged. Please charge the battery before use.

① To install Battery Pack, proceed as follows:

-Insert the Battery Pack in the direction of the arrow.

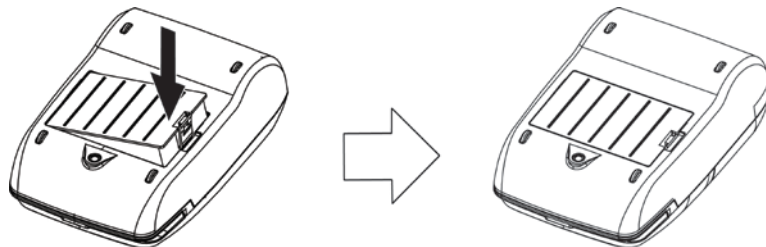

② To remove battery pack, proceed the above order reverse.

2.5.3. Recharging the battery pack

For recharging the battery pack, install the battery pack in the printer.
Insert the USB connector of the printer. (Use cable of USB C type.)

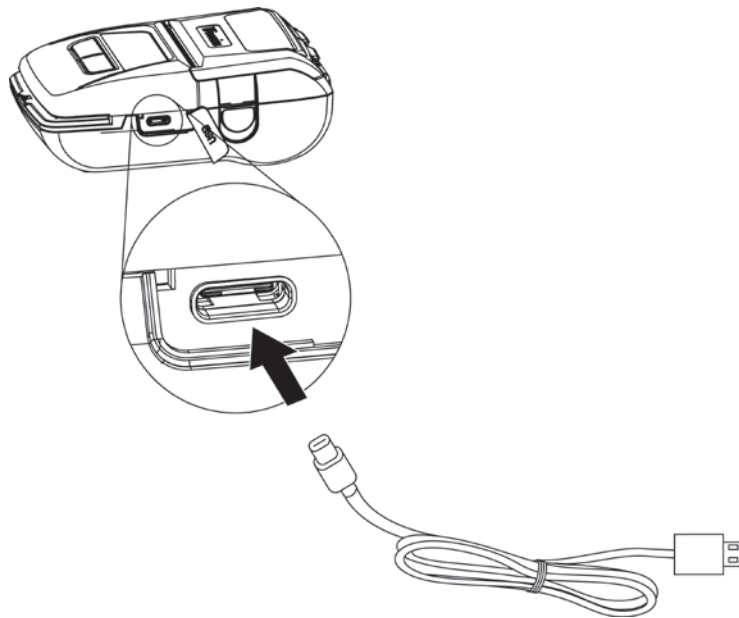

- NOTE :**
- While charging the printer, turn off the printer power.
 - Do not remove the battery during charging.
 - The battery is consumable parts and when purchasing, compared to the use hour is gradually decreases. (Warranty 6 month)
 - The recharging time depends on the voltage level and ambient temperature of the battery.
Normally, it takes about 3 hours to recharge a battery pack.

2.6. Set operation mode

In keeping on pressing the Feed and Power button simultaneously until after the **OLED Backlight(Blue)** blinks 5 times, the printer comes out at the circumstance to change the printer mode. (refer Table 2)

- **FEED button** : changing Printer MODE status.
- **POWER button** : changing OPTION status.

***Note**

No additional mode settings are required to connect Android or iOS devices.

** If you want to change the Bluetooth Mode of printer, you need to disconnect the Bluetooth function of the current paired Smartphone.

**** Methods :**

1. Turn off the Bluetooth function of the current paired Smartphone.
(Bluetooth ICON in OLED is disappeared.)
2. Change the printer mode.
(Additionally, we want to recommend you to rest(OFF→ON) the printer and change mode.)

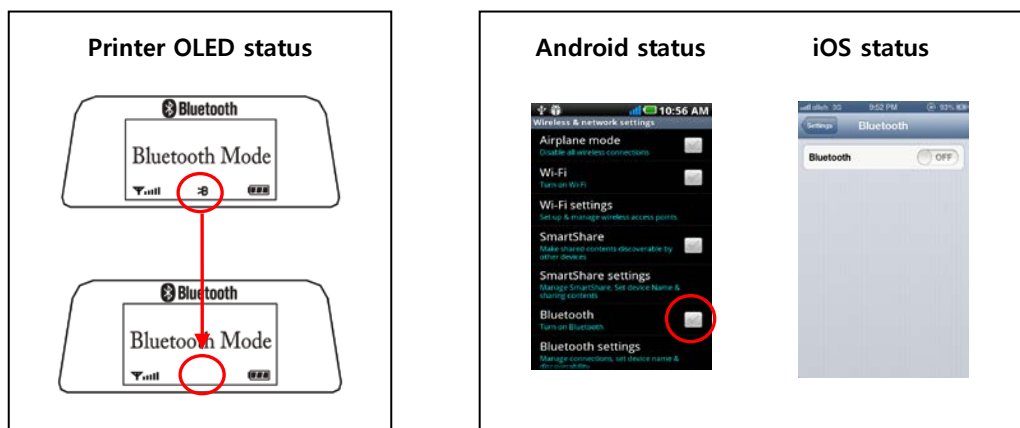

[Example] The defaults of the printer are :

USB / Density Low / Mark No Use / Sensor High / PWDN 5 min slp

If a user wants to modify the defaults with

Bluetooth / Density High / Mark Use / Sensor Low / PWDN No Use

- ▶ Press FEED & POWER Button during the **OLED backlight** flickers 5 times.
 - You will see present **COMMUNICATION** mode in the OLED. (USB)
 - Press the **POWER Button** twice. And then, interface mode has set to **Bluetooth** mode.
- ▶ When you press **FEED button** once.
 - You will see present **DENSITY** mode in the OLED. (Density low)
 - Press **POWER Button** twice. And then the density has set to **Density high**.
- ▶ When you press **FEED button** once.
 - You will see present **MARK** mode in the OLED. (No Use)
 - Press **POWER Button** once. And then the mark has set to **Mark Use**.
- ▶ When you press **FEED button** once.
 - You will see present **SENSOR** mode in the OLED. (High)
 - Press **POWER Button** once. And then the sensor has set to **Sensor Low**.
- ▶ When you press **FEED button** once.
 - You will see present **PWDN** mode in the OLED. (5 min slp)
 - Press **POWER Button** six times. And then the Power down has set to **PWDN No Use**.

If all the mode have set, press the **POWER Button** and the **FEED Button** at the same time.
After then release the buttons at the same time.

Bluetooth / Density High / Mark Use / Sensor Low / PWDN No Use

2.7. Memory switch table

Mode		Option	Etc.	Mode		Option	Etc.	
1	Communi- cation Port	1	USB	5	Power Down	1	No use	V
		2	USB(Pro)			2	1min Sleep	
		3	Bluetooth			3	2min Sleep	
		4	Bluetooth(Pro)			4	3min Sleep	
		5	Bluetooth(iAP)			5	4min Sleep	
2	Density	1	Low			6	5min Sleep	
		2	Medium			7	1min Off	
		3	High			8	2min Off	
3	Mark	1	No use			9	3min Off	
		2	Use			10	4min Off	
4	Sensor sensitivity	1	Low			11	5min Off	
		2	Medium1					
		3	Medium2					
		4	High					

< Table 2 >

Notice : Bluetooth(iAP) is the mode which is used in iPod, iPhone and iPad Whole aspect.

Etc. (V): no function due to the specification of the product.

3. Interface

3.1. USB

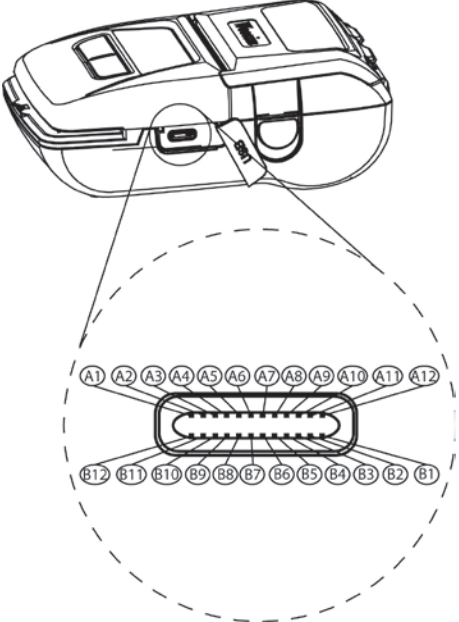

The WSP-L240 printer has a USB interface and is connected by means of a USB "C" type socket. In the following table, the signals present on the USB C type socket are listed:

Pin No.	Name	Function
A9, B4	VBUS	USB +5V
A7,B7	D-	DATA "-"
A6,B6	D+	DATA "+"
A1,A12 B1,B12	GND	Ground

NOTE : ● If you connect the printer interface cable is converted to USB mode.
● When data receiving, when it removes the communication cable, it loses a data.

3.2. Bluetooth

Category	Specification
Bluetooth Spec.	Classic(V3.0) and BLE(V4.1) / Class2 (10m)
Frequency band	2400~2483 MHz
Protocol	L2CAP, RFCOMM, SDP
Profile	GATT, GAP, SDAP, SPP

3.3. Read a magnetic stripe card

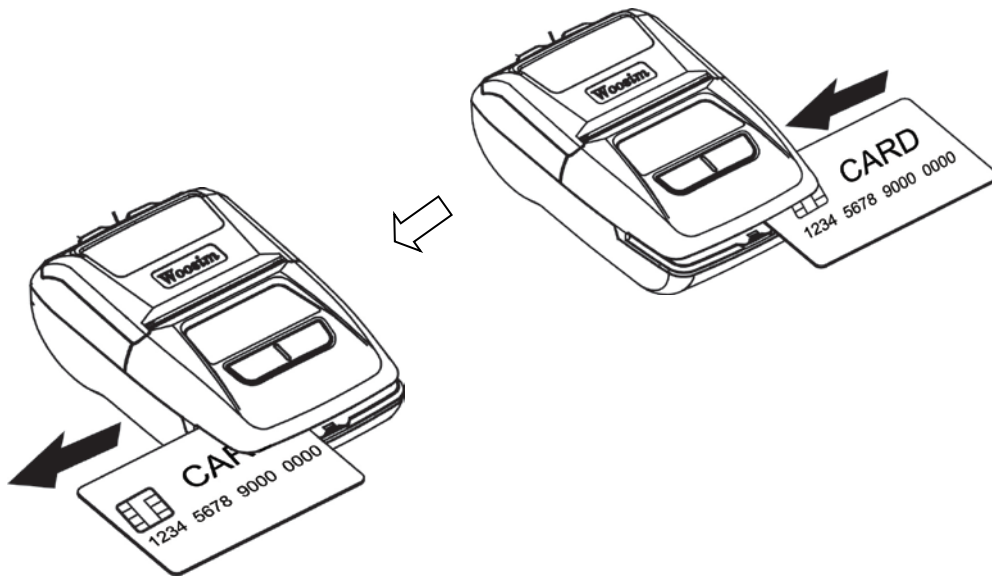

- ▶ Check the direction of the magnetic stripe and read the card.
- ▶ Holding the card as shown above, please pass at a steady speed.
(check the direction of the arrow.)
- ▶ When the card reading is successful, buzzer sound one time.
If it fails, buzzer sounds three times.

4. Using the printer

4.1. Control panel

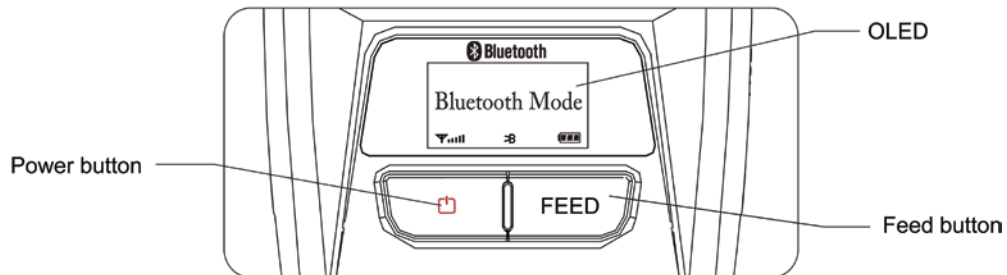

► BUTTON

- **FEED Button** : Use to feed paper continuously.
- **POWER Button** :
 - ① When of 5 or more seconds presses and power comes to on or off.
 - ② After pressing the POWER and the FEED button simultaneously, if the ERROR lamp 5 turn signals POWER button is converted with MODE functions.
- In keeping on pressing the **Feed and Power button** simultaneously until after the **OLED backlight** blinks 5 times, the printer comes out at the circumstance to change the printer mode.
(Refer to **2.6. Set operation mode** for details about mode conversion)

► OLED

- OLED will display most of the printer status.
(details: current printer status, paper out, indicated remaining battery, communication connection etc.)

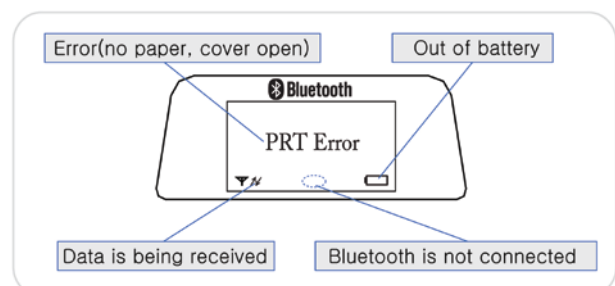
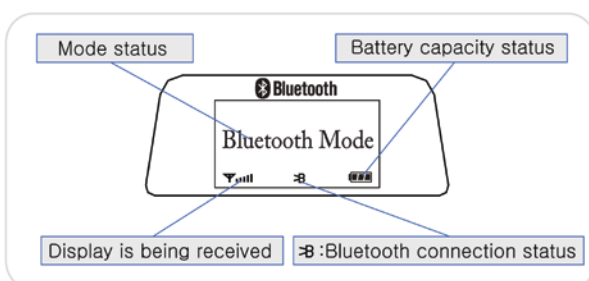

4.2. The self test

Self-Test prints out the current setting value of printer. The way of self-test is as follows.

1. Insert proper paper into the printer.
2. Power on while pressing feed button to start self-test.
3. Printer will print out the current status. (F/W version and set contents)
4. And then pattern of characters will be printed out.
5. Self-test will be finished automatically and turned to the standby status.

※ In case printer does not work properly, please contact Woosim customer service center.

4.3. Using the Belt clip

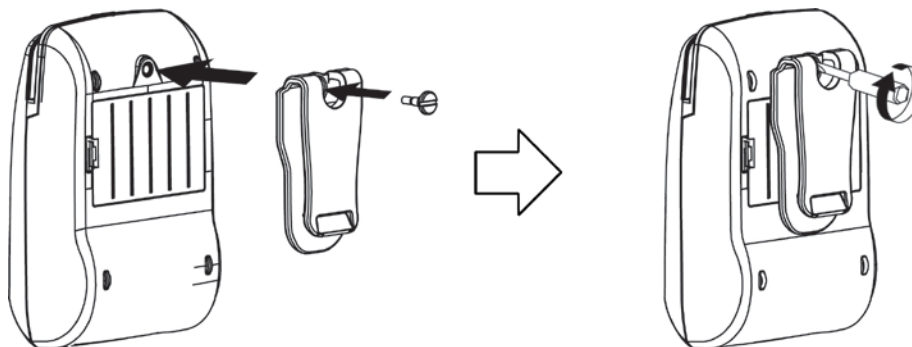

Following the instruction of the arrow, please put the belt clip in the hole and turn and fix the screw to the right by using a screw driver.

Afterward, you can use it like the picture below.

5. Consumable Parts.

5.1. Recommended paper.

Type	: Thermal Paper
Paper width	: 58mm
Paper thickness	: $60 \pm 5 \mu\text{m}$
Outer diameter	: $\text{Ø}40\text{mm}$ or less
Recording side	: Outside of roll



Cautions

1. Do not paste the paper to the core. And the roll paper which has Near end mark printing on its near end is recommended.
2. Chemicals or oil may change the color of paper, or printed Characters may fade.
3. Change of paper color starts from approx 70 °C.
Pay attention to heat, humidity and sun light.
4. Color of paper may be changed by being scratched by nail or hard metal, etc

5.2. Printing position.

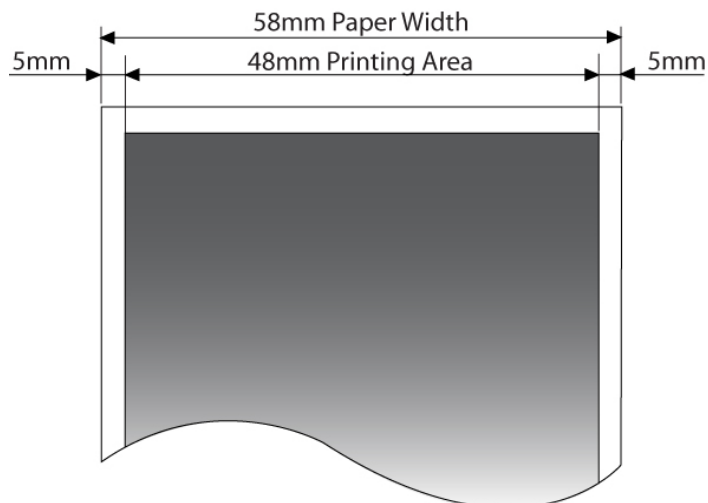

6. Revision History

Date	Version	Comments
Feb. 03. 2020	1.0	Initialize