

**MODEL** **PORTI-W25**

**(Mobile Printer)**

**Rev. 2.0**

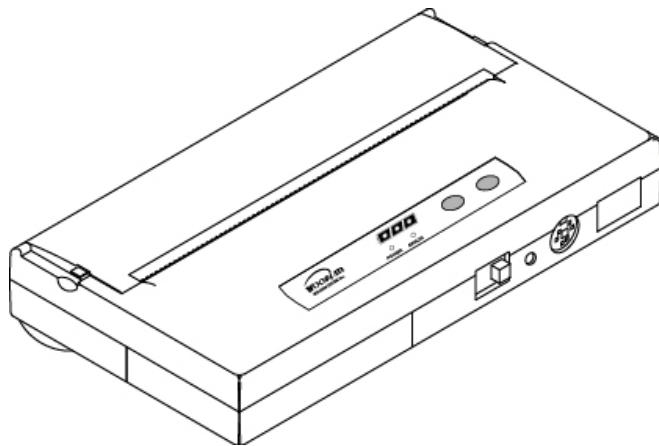

**WOOSIM SYSTEMS Inc.**

**#501, Daerung Technotown 3th, 448,  
Gasam-Dong, GeumChun-Ku, Seoul,  
Korea**

**Tel : +82-2-2107-3700**

**Fax : +82-2-2107-3707**

**URL** <http://www.woosim.com>

All specifications are subjected to change without notice

## ! Copyright

**PORTI-W25** Mobile printer operator's manual.

Copyright 2007 by Woosim Systems Inc.

All rights reserved.

The information contained in this manual is the property of Woosim System Inc. and may not be reproduced in whole or in part without the prior written permission of Woosim System Inc.

## ! Trademark



a registered trademark of Woosim Systems Inc.

All other trademark are the properties of their respective companies.

## ! Caution

Some semiconductor devices are easily damaged by static electricity. You should turn the printer "OFF", before you connect or removed the cable on the rear side, in order to guard the printer against the static electricity.

If the printer is damaged by the static electricity, you should turn the printer "OFF".

## ! Notice

The contents of this manual are subject to change without notice.

## ! Introduction

The **PORTI-W25s** suitable designed for use with a growing variety of mobile devices. IrDA/Serial or Bluetooth/Serial interfaces make the PORTI-W25 the perfect comrade for applications such as point of transaction warehousing, distribution, point of sales, hospitality, gaming and healthcare.

The general features of PORTI-W25 printer are as follows:

- U Pocket size (138mm x 88mm x 24mm).
- U Light weight(340g) for true mobility.
- U Very silent printing thru direct thermal printing method.
- U High speed (50mm/sec, MAX)
- U High resolution (203dpi, 8dot/mm)
- U UART(RS-232C or TTL) , Bluetooth Ver2.1 + EDR interface
- U IrDA Ver 1.0(SIR) [option], USB [option] interface
- U Intuitive LED's indicate Power(on/off),Error and Battery status
- U Support text and graphic printing
- U Easier paper roll loading by CLAMSHELL design.
- U Easier maintenance with self-diagnostic.
- U In field programming – Update Firmware, Download Fonts and Logos
- U Microsoft Windows 98 / ME / 2000 / XP / VISTA / 7 compatible.
- U Free fall: 1 meter onto concrete (option 1.5 meter)
- U Flow control : Software (XON/XOFF)  
Hardware flow control not supported in printer.
- U Agency Approvals



## ! Operating Precautions

Please follow the precautions below to enjoy and maintain the full performance of the printer.

### U Using the Printer

- Be careful not to drop or bump the printer on a hard surface.
- Do not install the printer in direct sunlight or such areas.

Suitable environment for the use of the printer is as follows:

Operating temperature :-10°C to 50°C

Relative humidity : 10% to 90% (No condensation)

- Do not install the printer near devices that generate strong electromagnetic fields such as a copy machine.
- Do not open the platen cover during printing .
- Do not remove or reinstall the communication cable during printing or transmission.
- Do not touch the connectors of the communication during printing.
- Switch the POWER OFF when not in use.
- Do not use alcohol or other solvent.
- The AC adapter, the battery charger and the battery pack may become warm when in use. This is normal and is not a malfunction.
- When the battery pack is used at low temperature, the length of time the printer can be used may be shortened.

### U Thermal Paper Handling

- Store the thermal paper in a cool, dry and dark place.
- Do not rub the paper with hard object.
- Do not leave the paper with hard object.
- Do not allow plastic film, erasers, or adhesive tape to touch the paper for long periods.
- Do not stack the thermal paper with diazo copies immediately after copying or wet-type copies.
- Do not use chemical glue.
- Always use the clean thermal paper.

**| Note**

This equipment has been tested and found to comply with the limits for a Class B digital device, pursuant to Part 15 the FCC Rules.

These limits are designed to provide reasonable protection against harmful interference in a residential installation.

These equipment generates, uses and can radiate radio frequency energy and, if not installed and used in accordance with the instructions, may cause harmful interference to radio communications.

However, there is no guarantee that interference will not occur in a particular installation.

If this equipment does cause harmful interference to radio or television reception , which can be determined by turning the equipment off and on, the user is encouraged to try to correct the interference by one or more of the following measures:

- Reorient or relocate the receiving antenna.
- Increase the separation between the equipment and receiver.
- Connect the equipment into an outlet on a circuit different from that to which the receiver is connected.
- Consult the dealer or an experienced radio/TV technician for help.

# CONTENTS

<b>1. Outline</b> .....	7
1.1. Model classifications .....	7
1.2. Product Part Number System.....	7
1.3. Specifications.....	8
<b>2. Setting up the printer</b> .....	9
2.1. Printer & Accessories .....	9
2.2. Printer Features .....	10
2.2.1. Part name .....	10
2.2.2. Dimensions .....	10
2.3. Replacing the paper roll.....	11
2.4. Power supply .....	12
2.4.1. Internal power supply .....	12
2.4.2. Installing the Battery.....	12
2.4.3. Recharging the battery pack.....	13
2.5. Set operation mode .....	14
<b>3. Interface</b> .....	24
3.1. UART(RS-232C or TTL) or USB .....	24
3.2. Infrared data communication .....	25
3.3. Bluetooth .....	26
<b>4. Using the printer</b> .....	27
4.1. Control panel .....	27
4.2. Self test .....	28
<b>5. Consumable parts</b> .....	29
5.1. Recommended paper.....	29
5.2. Printing position.....	29

# 1. Outline

## 1.1. Model classifications

**PORTI-W25** ( ) ( )

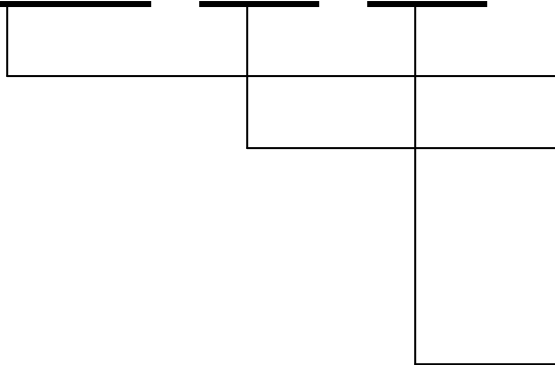

**Model Name**

**Interface**

None : IrDA/UART

U : USB/UART

BT : Bluetooth/UART

**Power**

None : DC 8.4V

## 1.2. Product Part Number System

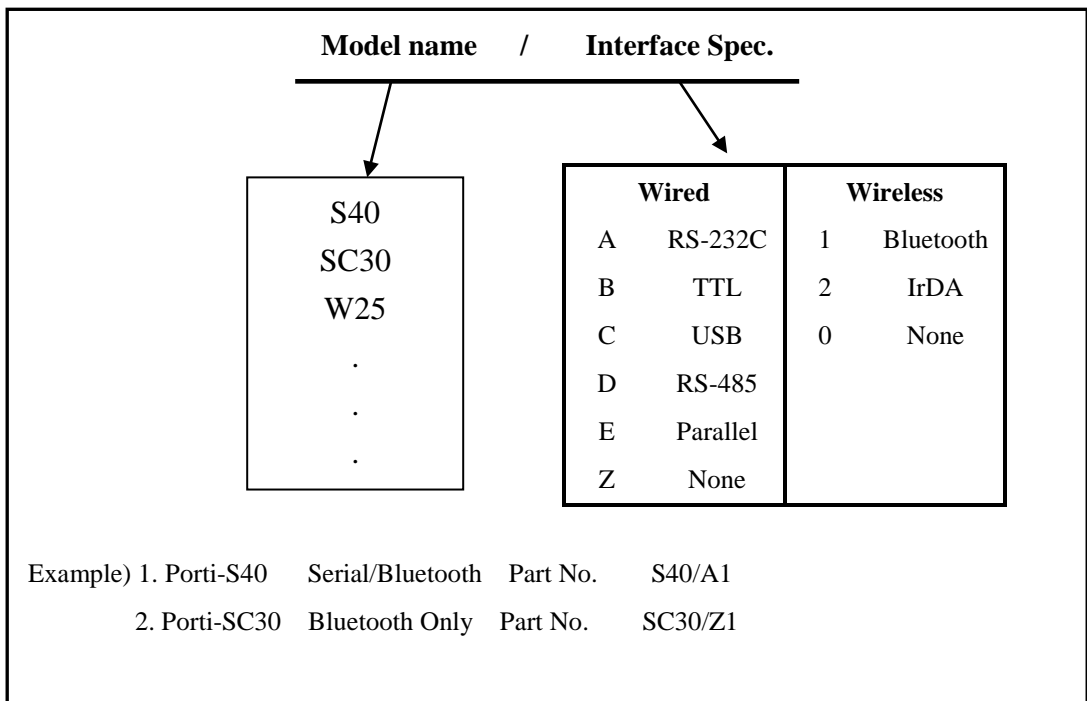

## 1.3. Specifications

Item	Specification	
<b>Printing method</b>	Direct thermal line printing	
<b>Characters per line</b>	92cpl (MAX)	
<b>Character size</b>	Eng. : 9*24dots, 12*24dots    Kor. : 16*24dots, [24*24dots]	
<b>Optional Characters</b>	Simplified/Traditional Chinese, Arabic, Cyrillic, Russian, Turkish, Greek, Japanese, Persian, Latin9 and Others upon request.	
<b>Resolution</b>	203dpi, 8dots/mm	
<b>Print width</b>	4-inch (104mm, 832dots)	
<b>Printing speed</b>	50mm / sec (MAX)	
<b>Dimensions</b>	138 * 88 * 24 mm	
<b>Weight</b>	340g (Including battery & roll paper)	
<b>Interface</b>	UART(RS-232C or TTL), Bluetooth Ver2.1 + EDR IrDA Ver1.0(SIR) [option], USB [option]	
<b>Paper supplied</b>	Thermal roll paper (117mm wide, 25ø)	
<b>Barcode supplied</b>	1-dimension : Code128, Code39, I2/5, Code93 UPC, EAN, KAN, JAN, CODABAR 2-dimension : PDF417, QR Code, DATA Matrix	
<b>Black mark</b>	Support black mark detection	
<b>H/W spec.</b>	MCU : 32bits RISC, FLASH : 4Mbytes, RAM : 8Mbytes	
<b>Receive buffer size</b>	1M bytes	
<b>Battery</b>	Rechargeable 7.4V DC , 1400mAh(Li-ion)	
<b>Battery duration</b>	1 hour continuous printing	
<b>Battery Charger</b>	Input (100~250V AC 50~60Hz) Output(8.4VDC/0.8A), 4hours full charge time	
<b>Environment Conditions</b>	Temperature	-10°C ~ 50°C (operating) -10°C ~ 70°C (storage)
	Humidity	30% - 80% (operating) 10% - 90% (storage)
<b>MCBF (Mean Cycle Between failure)</b>	Mechanical	37,000,000 lines
	Head	Approximately 50 Km

&lt; Table 1 &gt;

## 2. Setting up the printer

### 2.1. Printer & Accessories

When unpacking your printer box make sure it contains the printer and all accessories. If any accessories are missing or damage, please contact your dealer for assistance.

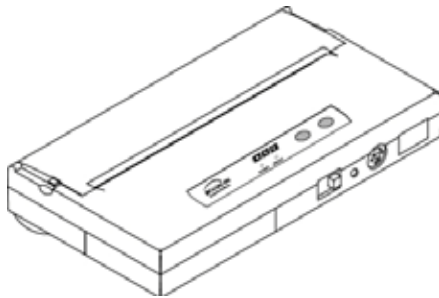

**PORTI-W25**

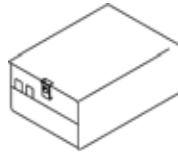

**Battery pack**



**Thermal roll paper**



**Battery charger adapter**

#### OPTIONAL

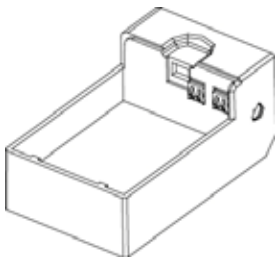

**Battery holder**



**Communication cable**



**Car charger**

## 2.2. Printer Features

### 2.2.1. Part name

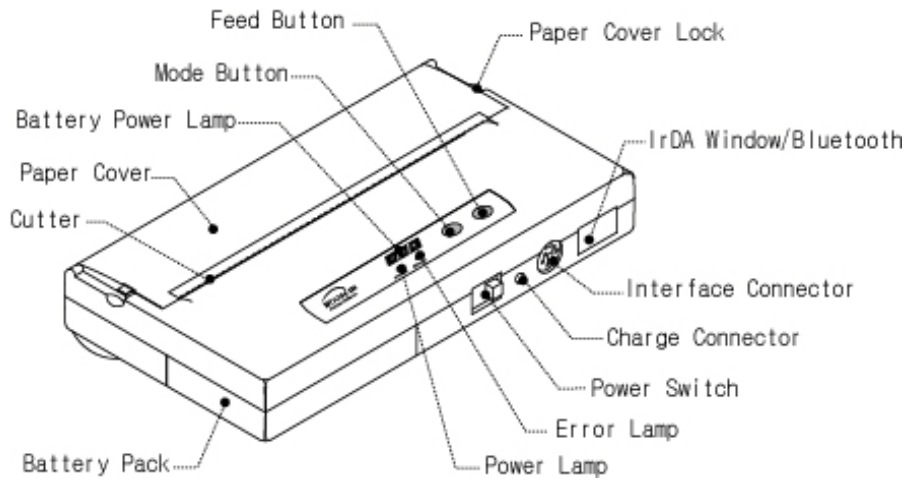

### 2.2.2. Dimensions

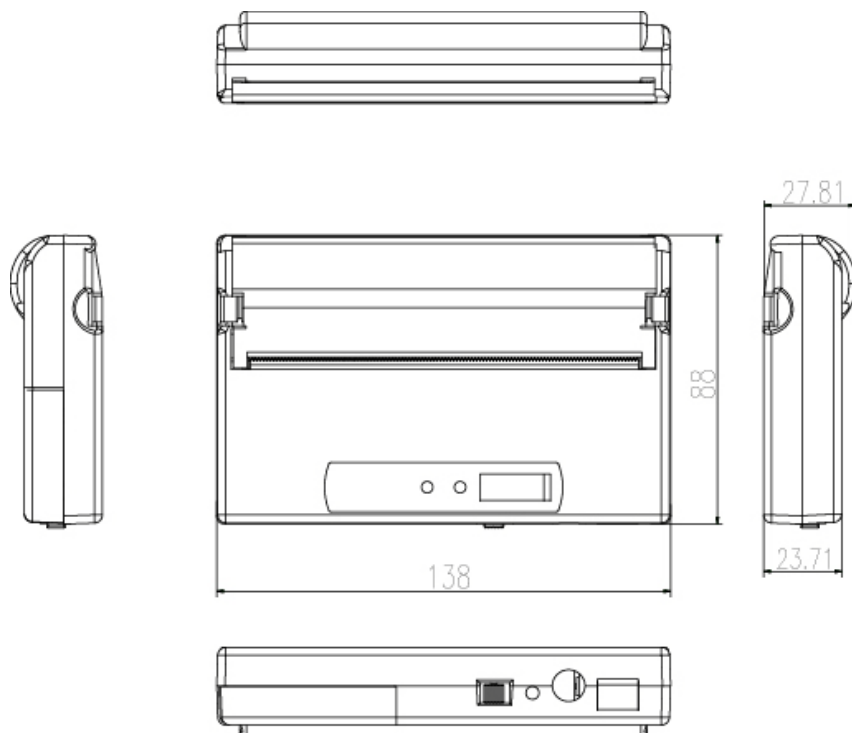

## 2.3. Replacing the paper roll

Note : Be sure to use paper rolls that meet the specifications.

Do not use paper rolls that have the paper glued to the core because the printer can not detect the paper end correctly.

1. Make sure that the printer is not receiving data; otherwise, data may be lost.
2. Open the paper cover using finger on both side of printer, and remove the remaining paper.

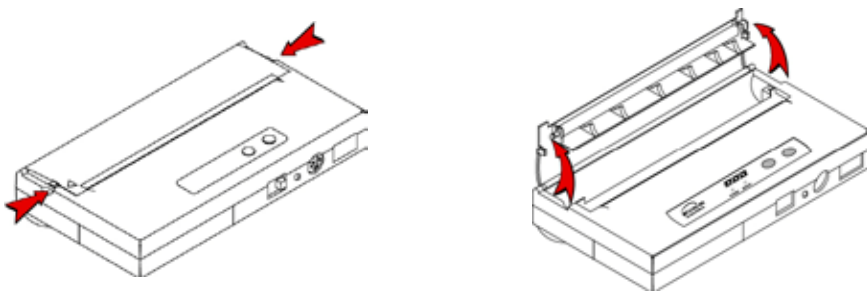

3. Insert the paper roll as shown.

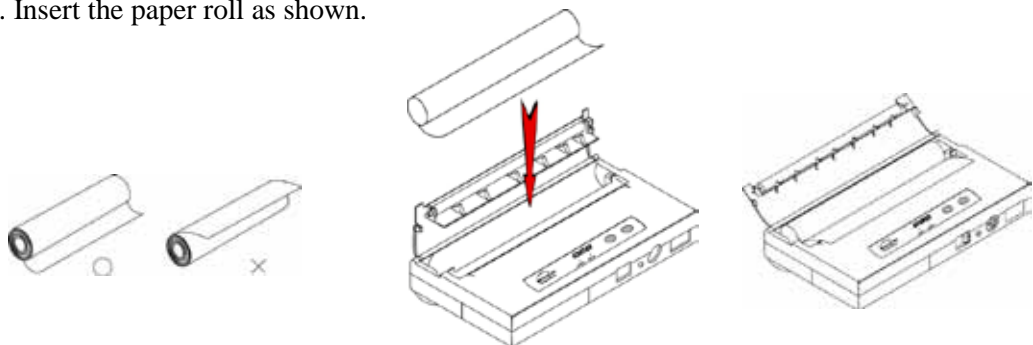

4. Tear the excess paper off using the edge of paper door as a tear bar.

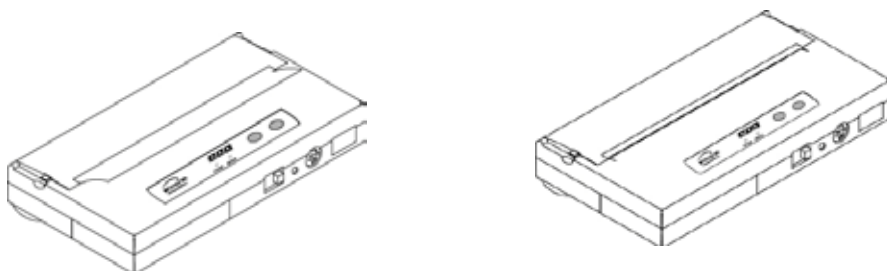

## 2.4. Power supply

### 2.4.1. Internal power supply

The following specification is requested for Power supply.

Battery Charger : DC 8.4V/0.8A

Avoid using power supply which its power capacity of power current is extremely high.

### 2.4.2. Installing the Battery

- NOTE :**
- **Before installing or removing the battery pack, ensure the printer is OFF.**
  - **If the printer is not used for long period of time, remove the battery pack from the printer.**

To install the battery pack, proceed as follows:

- Insert the battery pack in the direction of the arrow.

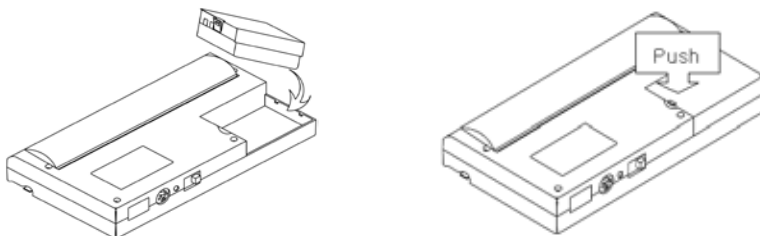

Removing the battery pack , proceed as follows:

- Turn the printer power off and push the battery pack lock and to lift up the direction of the arrow.

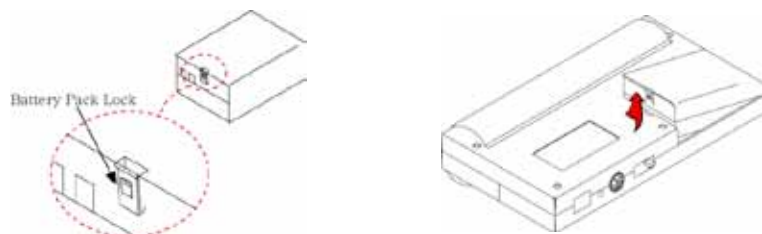

The battery pack install into battery holder.

- Insert the battery pack in the direction of the arrow.

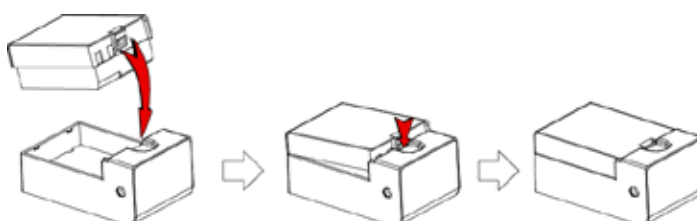

### 2.4.3. Recharging the battery pack

For recharging the battery pack, install the battery pack in the printer or the battery holder.

Insert the battery charger adaptor to the charge connector of the printer or the battery holder.

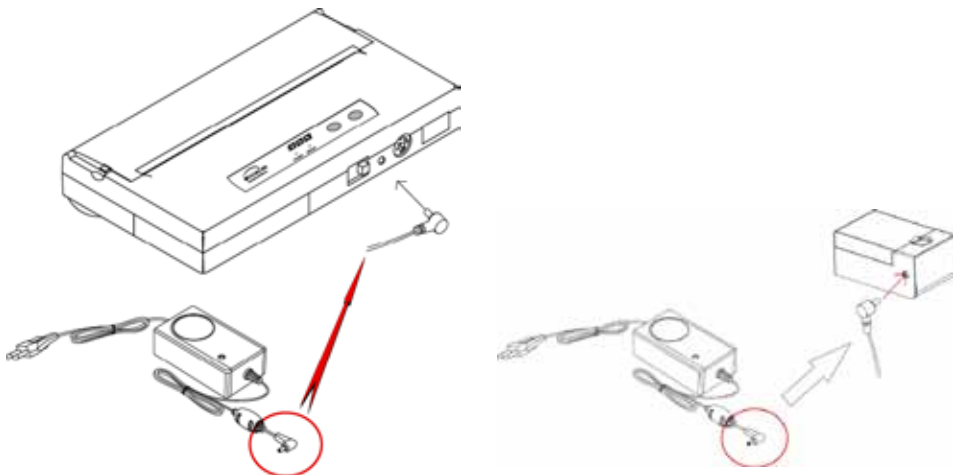

- NOTE :**
- While charging the printer, turn off the printer power.
  - Do not remove the battery during charging.
  - The battery is consumable parts and when purchasing, compared to the use hour is gradually decreases. (Warranty 6 month)
  - If the printer is not used for a long time, unplug the power cord from the printer and outlet.
  - The recharging time depends on the voltage level and ambient temperature of the battery. Normally, it takes about 4 to 5 hours to recharge a battery pack.
  - You must use only the supplied adapter.
  - Red Lamp : charging the battery.  
Green Lamp: charging is finished.

## 2.5. Set operation mode

### < M37702 (OLD) Version >

Change the mode and option using the MODE Code.

- | **MODE button** : use for changing OPTION status. (Error Lamp)
- | **FEED button** : use for changing MODE status. (Power Lamp)

[Example] The defaults of the printer are :

RS-232C / 9600 bps / 8 data bit / No parity / Density low / Mark use / Sensor low

If a user wants to modify the defaults with

Bluetooth / 57600 bps / 7 data bit / Odd parity / Density high / Mark no use

/ Sensor Medium1

U Press **MODE Button** during the **Error Lamp** flicking 5 times.

Ⓜ You will see the **Power Lamp** and the **Error Lamp** flickers once.

Ⓜ Press the **MODE Button** twice and the **Error Lamp** flickers 3 times.

And then, interface mode has set to **Bluetooth** mode.

U When you press **FEED button** once again, **Power Lamp** flickers twice and the **Error Lamp** flickers 4 times.

Ⓜ Press **MODE Button** 3 times, **Error Lamp** flickers 7 times.

And then, baudrate has set to **57,600 bps**.

U When you press **FEED Button** once again, **Power Lamp** flickers 3 times and the **Error Lamp** flickers twice.

Ⓜ Press **MODE Button** once, **Error Lamp** flickers once.

And then Data Bit has set to **7 data bit**.

U When you press **FEED Button** once again, **Power Lamp** flickers 4 times and the **Error Lamp** flickers once.

Ⓜ Press **MODE Button** twice, **Error Lamp** flickers 3 times.

And then the Parity bit has set to **Odd parity bit**.

U When you press **FEED Button** once again, **Power Lamp** flickers 5 times and **Error Lamp** flickers once.

Ⓜ Press **MODE Button** twice, **Error Lamp** flickers 3 times.

And then the density has set to **Density high**.

- ⌋ When you press **FEED Button** twice, **Power Lamp** flickers 7 times and **Error Lamp** flickers twice.
- Ⓜ Press **MODE Button** once, **Error Lamp** flickers twice.  
And then the mark has set to **Marm no use**.
- ⌋ When you press **FEED Button** once again, **Power Lamp** flickers 8 times and **Error Lamp** flickers once.
- Ⓜ Press **MODE Button** once, **Error Lamp** flickers twice.  
And then the sensor has set to **Sensor medium1**.

If all the mode have set, press the **MODE Button** and the **FEED Button** at the same time after then release the buttons at the same time.

The printer will print out the mode status which has modified.

( **Bluetooth / 57,600 baud / 7 data bit / Odd parity / Density high / Mark no use / Sensor medium1** )

If the status is not correct, please try it again according to the procedure.

**\* M37702 ( OLD ) IrDA Version**

<b>MODE</b>	<b>POWER Lamp (Green)</b>	<b>ERROR Lamp (Red)</b>	<b>Option</b>
<b>Communication Port</b>	1	1	RS-232C
		2	Protocol IrDA
		3	Standard IrDA
<b>Baud Rate</b>	2	1	1200 bps
		2	2400 bps
		3	4800 bps
		4	9600 bps
		5	19200 bps
		6	38400 bps
		7	57600 bps
		8	115200 bps
<b>Data Bit</b>	3	1	7 Data bit
		2	8 Data bit
<b>Parity Bit</b>	4	1	No Parity
		2	Even Parity
		3	Odd Parity
<b>Density</b>	5	1	Density Low
		2	Density Medium
		3	Density High
<b>Protocol</b>	6	1	Default Protocol
		2	Lotte Protocol
<b>Mark</b>	7	1	No use
		2	Use
<b>Sensor</b>	8	1	Low
		2	Medium1
		3	Medium2
		4	High

&lt; Table 2 &gt;

**\* M37702 ( OLD ) Bluetooth Version**

<b>MODE</b>	<b>POWER Lamp (Green)</b>	<b>ERROR Lamp (Red)</b>	<b>Option</b>
<b>Communication Port</b>	1	1	RS-232C
		2	Protocol Bluetooth
		3	Bluetooth
<b>Baud Rate</b>	2	1	1200 bps
		2	2400 bps
		3	4800 bps
		4	9600 bps
		5	19200 bps
		6	38400 bps
		7	57600 bps
		8	115200 bps
<b>Data Bit</b>	3	1	7 Data bit
		2	8 Data bit
<b>Parity Bit</b>	4	1	No Parity
		2	Even Parity
		3	Odd Parity
<b>Density</b>	5	1	Density Low
		2	Density Medium
		3	Density High
<b>Protocol</b>	6	1	Default Protocol
		2	Lotte Protocol
<b>Mark</b>	7	1	No use
		2	Use
<b>Sensor</b>	8	1	Low
		2	Medium1
		3	Medium2
		4	High

&lt; Table 3 &gt;

## &lt; M16C, ARM ( NEW ) Version &gt;

Change the mode and option using the MODE Code.

- | **MODE button** : use for changing OPTION status. (Error Lamp)
- | **FEED button** : use for changing MODE status. (Power Lamp)

[Example] The defaults of the printer are :

RS-232C / 9600 bps / 8 data bit / No parity / 1 stop bit / Density low  
/ Mark use / Sensor low / Power down 5 minute

If a user wants to modify the defaults with

Bluetooth / 57600 bps / 7 data bit / Odd parity / 2 stop bit / Density high  
/ Mark no use / Sensor medium1 / Power down no use

U Press **MODE Button** during the **Error Lamp** flicking 5 times.

Ⓜ You will see the **Power Lamp** and the **Error Lamp** flickers once.

Ⓜ Press the **MODE Button** twice and the **Error Lamp** flickers 3 times.

And then, interface mode has set to **Bluetooth** mode.

U When you press **FEED button** once again, **Power Lamp** flickers twice and the **Error Lamp** flickers once.

Ⓜ Press **MODE Button** 3 times, **Error Lamp** flickers 4 times.

And then, baudrate has set to **57,600 bps**.

U When you press **FEED Button** once again, **Power Lamp** flickers 3 times and the **Error Lamp** flickers twice.

Ⓜ Press **MODE Button** once, **Error Lamp** flickers once.

And then Data Bit has set to **7 data bit**.

U When you press **FEED Button** once again, **Power Lamp** flickers 4 times and the **Error Lamp** flickers once.

Ⓜ Press **MODE Button** once, **Error Lamp** flickers twice.

And then the Parity bit has set to **Odd parity bit**.

U When you press **FEED Button** once again, **Power Lamp** flickers 5 times and **Error Lamp** flickers once.

Ⓜ Press **MODE Button** once, **Error Lamp** flickers twice.

And then the density has set to **2 stop bit**.

- ⌚ When you press **FEED Button** once again, **Power Lamp** flickers 6 times and **Error Lamp** flickers once.
  - Ⓜ Press **MODE Button** twice, **Error Lamp** flickers 3 times.  
And then the density has set to **Density high**.
- ⌚ When you press **FEED Button** once again, **Power Lamp** flickers 7 times and **Error Lamp** flickers twice.
  - Ⓜ Press **MODE Button** once, **Error Lamp** flickers once  
And then the mark has set to **Mark no use**.
- ⌚ When you press **FEED Button** once again, **Power Lamp** flickers 8 times and **Error Lamp** flickers once.
  - Ⓜ Press **MODE Button** once, **Error Lamp** flickers twice  
And then the sensor has set to **Sensor medium1**.
- ⌚ When you press **FEED Button** once again, **Power Lamp** flickers 9 times and **Error Lamp** flickers five times.
  - Ⓜ Press **MODE Button** once, **Error Lamp** flickers once  
And then the power down has set to **Power down no use**.

If all the mode have set, press the **MODE Button** and the **FEED Button** at the same time after then release the buttons at the same time.

The printer will print out the mode status which has modified.

(Bluetooth / 57600 bps / 7 data bit / Odd parity / 2 stop bit / Density high / Mark no use / Sensor medium1 / Power down no use)

If the status is not correct, please try it again according to the procedure.

## \* M16C , ARM (NEW) IrDA Version

MODE	POWER Lamp (Green)	ERROR Lamp (Red)	Option
Communication Port	1	1	UART
		2	Protocol UART
		3	Raw IrDA
		4	Protocol IrDA
		5	Standard IrDA
Baud Rate	2	1	9600 bps
		2	19200 bps
		3	38400 bps
		4	57600 bps
		5	115200 bps
Data Bit	3	1	7 Data bit
		2	8 Data bit
Parity Bit	4	1	No Parity
		2	Odd Parity
		3	Even Parity
Density	5	1	Density Low
		2	Density Medium
		3	Density High
Mark	6	1	No use
		2	Use
Sensor	7	1	Low
		2	Medium1
		3	Medium2
		4	High

(Continue...)

	POWER Lamp (Green)	ERROR Lamp (Red)	Option
Power Down	9	1	No use
		2	1 minute
		3	2 minute
		4	3 minute
		5	4 minute
		6	5 minute

< Table 4 >

## \* M16C , ARM (NEW) Bluetooth Version

MODE	POWER Lamp (Green)	ERROR Lamp (Red)	Option
Communication Port	1	1	UART
		2	Protocol UART
		3	Bluetooth
		4	Protocol Bluetooth
Baud Rate	2	1	9600 bps
		2	19200 bps
		3	38400 bps
		4	57600 bps
		5	115200 bps
Data Bit	3	1	7 Data bit
		2	8 Data bit
Parity Bit	4	1	No Parity
		2	Odd Parity
		3	Even Parity
Density	5	1	Density Low
		2	Density Medium
		3	Density High
Mark	6	1	No use
		2	Use
Sensor	7	1	Low
		2	Medium1
		3	Medium2
		4	High

(Continue...)

	<b>POWER Lamp (Green)</b>	<b>ERROR Lamp (Red)</b>	<b>Option</b>
<b>Power Down</b>	9	1	No use
		2	1 minute
		3	2 minute
		4	3 minute
		5	4 minute
		6	5 minute

< Table 5 >

### 3. Interface

#### 3.1. UART(RS-232C or TTL) or USB

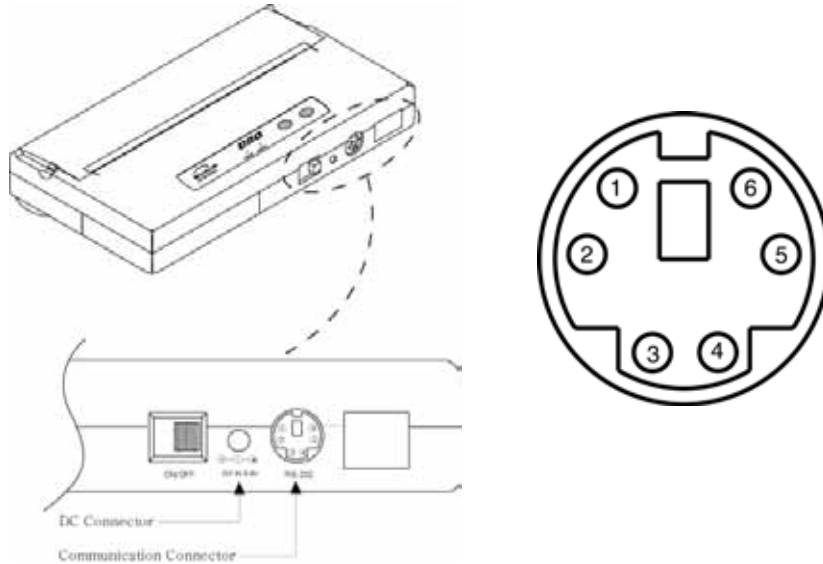

The PORTI-W25 printer has a UART(RS-232C or TTL) or USB interface is connected by means of a 6 pin mini din jack. In the following table, the signals present on the connector are listed:

UART(RS-232C or TTL)

Pin no	Signal Name	Direction	Function
1	GND		Ground
2	N.C		
3	N.C		
4	RxD	Input	Receive data
5	NC		
6	TxD	Output	Transmit data

USB

Pin no	Signal Name	Direction	Function
1	N.C		Ground
2	N.C		
3	GND		
4	DP		
5	VCC	-	5V
6	DM		

**NOTE :** ● When data receiving, when it removes the communication cable, it loses a data.

### 3.2. Infrared data communication

The PORTI-W25 has a serial interface for bi-directional data exchange.

The infrared port is the right side of the front part.

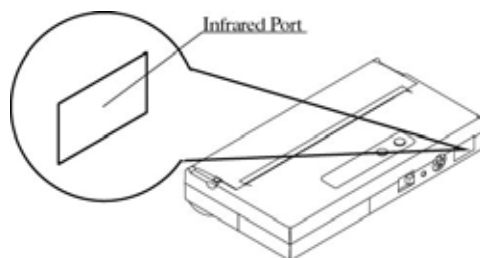

- 1) To use the PORTI-W25's infrared port, a computer or Personal Digital Assistant (PDA) with IR port is required.
- 2) Position a PDA conforming to the specifications in point not more than 50 centimeter away from the printer's infrared port. Make sure the two ports are in front of each other with an angle of not more than  $15^\circ$  on the four sides.

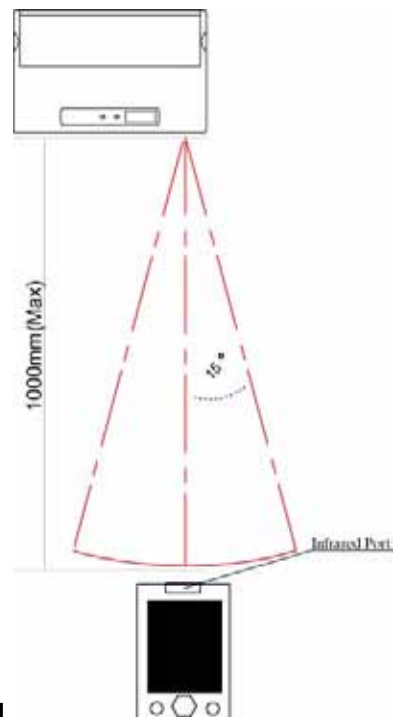

**NOTE :** ● When infrared ray communication doing, directness it does not see the IrDA window roll up.  
Eye damage there is a danger.

### 3.3. Bluetooth

Category	Specification
Bluetooth Spec.	Bluetooth Ver2.1 + EDR / Class2 (10m)
Frequency Range	2.4GHz ISM BAND
Data Transmission Rate	57600bps Fixed.
Data bit	8 Data bit Fixed.
Parity bit	No parity Fixed.
Stop bit	1 Stop bit Fixed.

## 4. Using the printer

### 4.1. Control panel

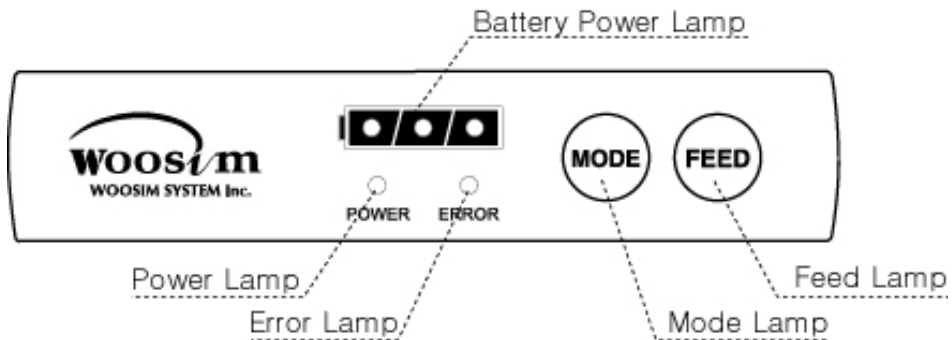

(Fig.2.1)

#### ⌋ Button

##### - FEED :

When the printer is on, paper can be feed manually by pressing and holding the FEED button for more than one second.

##### - MODE :

MODE Button is for use to change communication mode.

Do not operate the mode button without instructions.

#### ⌋ Panel lamp

- **Power** : Printer is ON and ready to receive data.

- **Error** : Indicates a fault condition or a printer error.

(i.e : no paper, paper cover opened. etc.)

- **Battery Power** : These lamps(**Green**) indicated the battery power remaining.

The battery gain in quantity and these lamps are on the decrease.

If so, you must recharge the battery by using the battery charger.

## 4.2. Self test

The Self-Test checks whether the printer has any problems.

If the printer does not function properly, contact your dealer.

For Self-Test, turn on the power while holding down the FEED Button.

The Self-Test checks the following :

- 1) Make sure paper roll has been installed properly.
- 2) The Self-Test prints the current printer status, which provides the control ROM version and the communication method setting.
- 3) After printing the current printer status, Self-Test will print a pattern using the built-in character set.
- 4) The Self-Test automatically ends.

The printer is ready to receive data as soon as it complete the Self-Test.

## 5. Consumable parts

### 5.1. Recommended paper

Type	: Thermal Paper
Paper width	: 117mm
Paper thickness	: $60\pm 5 \mu\text{m}$
Outer diameter	: $\text{Ø}25\text{mm}$ or less
Recording side	: Outside of roll



#### Cautions

1. Do not paste the paper to the core, and the roll paper which has near end mark printing on its near end is recommended.
2. Chemicals or oil may change the color of paper, or printed characters may fade.
3. Change of paper color starts from approx. 70 .  
Pay attention to heat, humidity and sun light.
4. Color of paper may be changed by being scratched by nail or hard metal, etc.

### 5.2. Printing position

