

MODEL **PORTI-ST30**

(Desk Top Printer)

Rev. 2.0

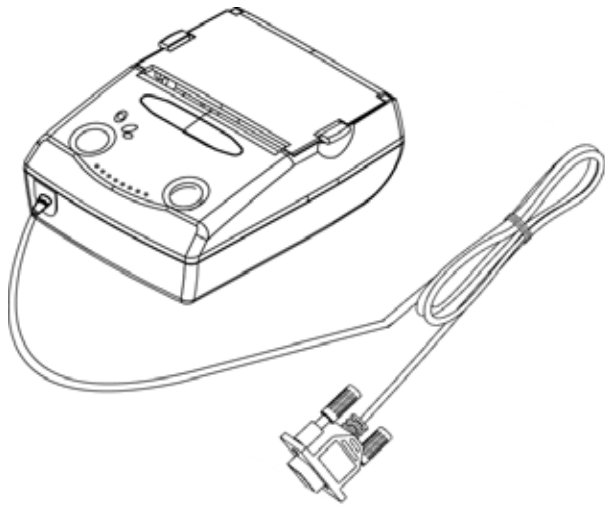

WOOSIM SYSTEMS Inc.

**#501, Daerung Technotown 3th, 448,
Gasan-Dong, GeumChun-Ku, Seoul,
Korea**

Tel : +82-2-2107-3700

Fax : +82-2-2107-3707

URL: <http://www.woosim.com>

All specifications are subjected to change without notice

! Copyright

PORTI-ST30 Desk Top printer operator's manual.

Copyright ©2007 by Woosim System Inc.

All rights reserved.

The information contained in this manual is the property of Woosim Systems Inc. and may not be reproduced in whole or in part without the prior written permission of Woosim Systems Inc.

! Trademark



a registered trademark of Woosim Systems Inc.

All other trademark are the properties of their respective companies.

! Caution

Some semiconductor devices are easily damaged by static electricity. You should turn the printer "OFF", before you connect or removed the cable on the rear side, in order to guard the printer against the static electricity.

If the printer is damaged by the static electricity, you should turn the printer "OFF"

! Notice

The contents of this manual are subject to change without notice.

| Introduction

The **Porti-ST30** is the ideal solution for taxi receipt printer, receipt printer, Medical analyzer, industrial instrument, recorder, geological analyzer, underground analyzer, chemical analyzer, metallic analyzer, etc.

The general features of Porti-ST30 printer are as follows:

- U Pocket size(75 * 95 * 35mm)
- U Light weight(169g) for true mobility.
- U Very silent printing thru direct thermal printing method
- U High speed(50mm/sec, MAX)
- U High resolution(203dpi : 8dots/mm).
- U UART(RS-232C or TTL) or RS-485 interface
- U Support text and graphic printing.
- U Low power consumption
- U Easier paper loading by CLAMSHELL design.
- U Easier maintenance with self-diagnostics.
- U In field programming – Update Firmware, Download Fonts and Logos
- U Flow control : Software (XON/XOFF)
Hardware flow control not supported in printer.
- U Agency Approvals



! Operating Precautions

Please follow the precautions below to enjoy and maintain the full performance of the printer.

U Using the Printer

- Be careful not to drop or bump the printer on a hard surface.
- Do not install the printer in direct sunlight or such areas.

Suitable environment for the use of the printer is as follows:

Operating temperature :-10°C to 50°C

Relative humidity : 10% to 90% (No condensation)

- Do not install the printer near devices that generate strong electromagnetic fields such as a copy machine.
- Do not open the platen cover during printing .
- Do not remove or reinstall the communication cable during printing or transmission.
- Do not touch the connectors of the communication during printing.
- Switch the POWER OFF when not in use.
- Do not use alcohol or other solvent.
- The AC adapter, the battery charger and the battery pack may become warm when in use. This is normal and is not a malfunction.
- When the battery pack is used at low temperature, the length of time the printer can be used may be shortened.

U Thermal Paper Handling

- Store the thermal paper in a cool, dry and dark place.
- Do not rub the paper with hard object.
- Do not leave the paper with hard object.
- Do not allow plastic film, erasers, or adhesive tape to touch the paper for long periods.
- Do not stack the thermal paper with diazo copies immediately after copying or wet-type copies.
- Do not use chemical glue.
- Always use the clean thermal paper.

CONTENTS

- 1. Outline6**
 - 1.1. Model classifications6
 - 1.2. Product Part Number System6
 - 1.3. Specifications7
- 2. Setting up the printer8**
 - 2.1. Printer & Accessories8
 - 2.2. Printer Features.....9
 - 2.2.1. Part name9
 - 2.2.2. Dimensions9
 - 2.3. Replacing the paper roll.....10
 - 2.4. Power supply11
- 3. Interface.....12**
 - 3.1. Serial.....12
- 4. Using the printer13**
 - 4.1. Control panel13
 - 4.2. The self test13
- 5. Consumable Parts14**
 - 5.1. Recommended paper14
 - 5.2. Printing position14

1. Outline

1.1. Model classifications

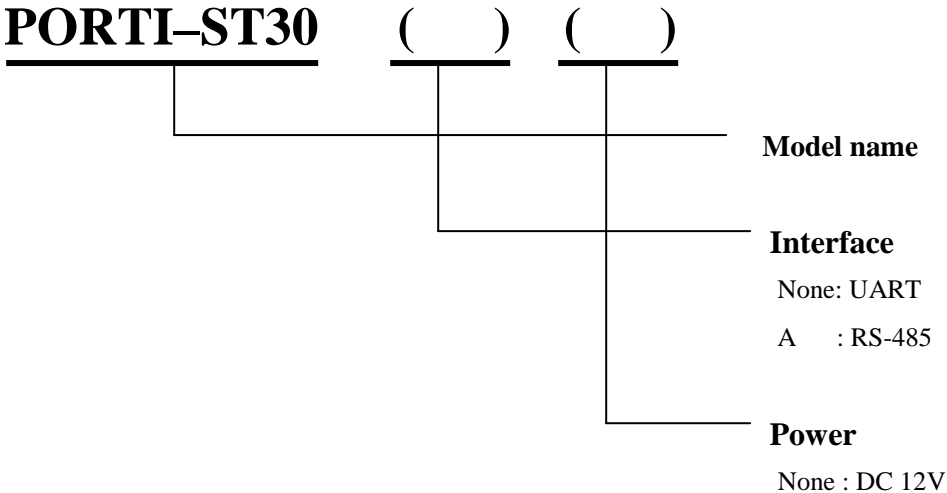

1.2. Product Part Number System

Model name / Interface Spec.

<p>S40 SC30 W25 . . .</p>	<table border="1" style="width: 100%; border-collapse: collapse;"> <thead> <tr> <th colspan="2">Wired</th> <th colspan="2">Wireless</th> </tr> </thead> <tbody> <tr> <td>A</td> <td>RS-232C</td> <td>1</td> <td>Bluetooth</td> </tr> <tr> <td>B</td> <td>TTL</td> <td>2</td> <td>IrDA</td> </tr> <tr> <td>C</td> <td>USB</td> <td>0</td> <td>None</td> </tr> <tr> <td>D</td> <td>RS-485</td> <td></td> <td></td> </tr> <tr> <td>E</td> <td>Parallel</td> <td></td> <td></td> </tr> <tr> <td>Z</td> <td>None</td> <td></td> <td></td> </tr> </tbody> </table>	Wired		Wireless		A	RS-232C	1	Bluetooth	B	TTL	2	IrDA	C	USB	0	None	D	RS-485			E	Parallel			Z	None		
Wired		Wireless																											
A	RS-232C	1	Bluetooth																										
B	TTL	2	IrDA																										
C	USB	0	None																										
D	RS-485																												
E	Parallel																												
Z	None																												

Example) 1. Porti-S40 Serial/Bluetooth Part No. S40/A1
 2. Porti-SC30 Bluetooth Only Part No. SC30/Z1

1.3. Specifications

Item	Specification	
Printing method	Direct thermal line printing	
Characters per line	42cpl (MAX)	
Character size	Eng. : 9*24dots, 12*24dots Kor. : 16*24dots, [24*24dots]	
Optional Characters	Simplified/Traditional Chinese, Arabic, Cyrillic, Russian, Turkish, Greek, Japanese, Persian, Latin9 and Others upon request.	
Resolution	203dpi, 8dots/mm	
Print width	2-inch (48mm, 384dots)	
Printing speed	50mm / sec (MAX)	
Dimensions	75 * 95 * 35 mm	
Weight	169g (including roll paper)	
Interface	UART(RS-232C or TTL) or RS-485	
Paper supplied	Thermal roll paper (57mm wide, 30ø)	
Barcode supplied	1-dimension : Code128, Code39, I2/5, Code93 UPC, EAN, KAN, JAN, CODABAR 2-dimension : PDF417, QR Code, DATA Matrix	
Receive buffer size	10K bytes	
Input Power	12VDC, Standby 60mA and Max 3A	
Environment Conditions	Temperature	-10°C ~ 50°C (operating) -10°C ~ 70°C (storage)
	Humidity	30% - 80% (operating) 10% - 90% (storage)
MCBF (Mean Cycle Between failure)	Mechanical	37,000,000 lines
	Head	Approximately 50 Km

< Table 1 >

2. Setting up the printer

2.1. Printer & Accessories

Your printer box should include these items.

If any items are damaged or missing, please contact your dealer for assistance.

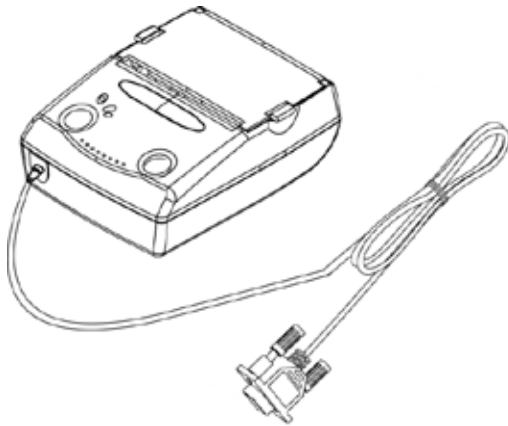

PORTI-ST30



Thermal roll paper

2.2. Printer Features

2.2.1. Part name

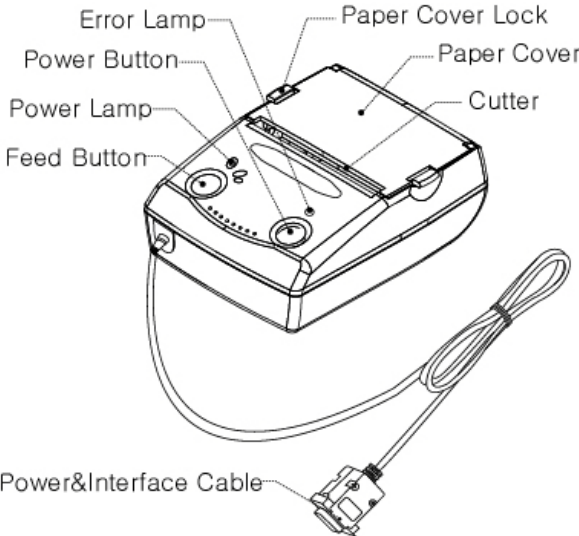

2.2.2. Dimensions

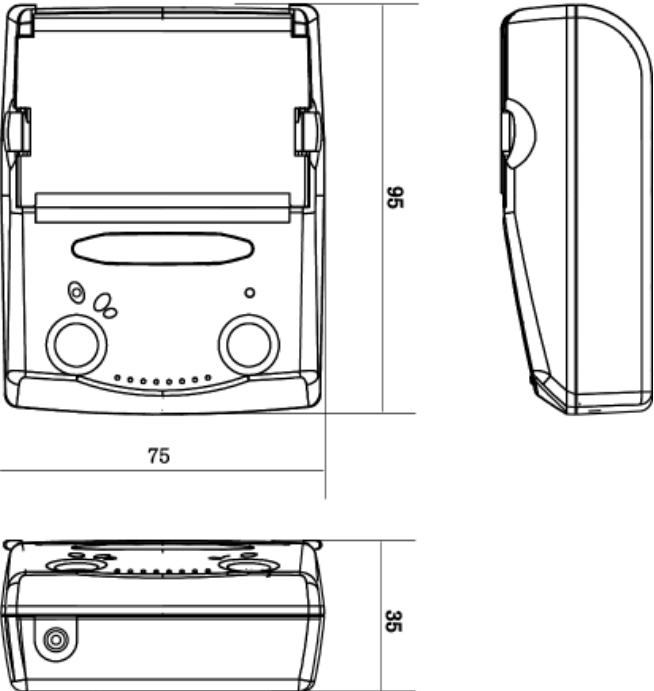

2.3. Replacing the paper roll

Note : Be sure to use paper rolls that meet the specifications.

Do not use paper rolls that have the paper glued to the core because the printer can not detect the paper end correctly.

1. Make sure that the printer is not receiving data; otherwise, data may be lost.
2. Open the paper cover using finger on both side of printer, and remove the remaining paper.

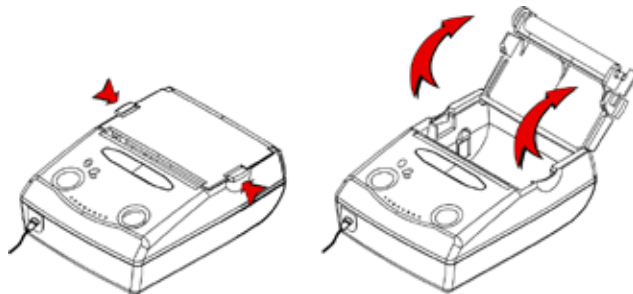

3. Insert a new paper roll as shown.

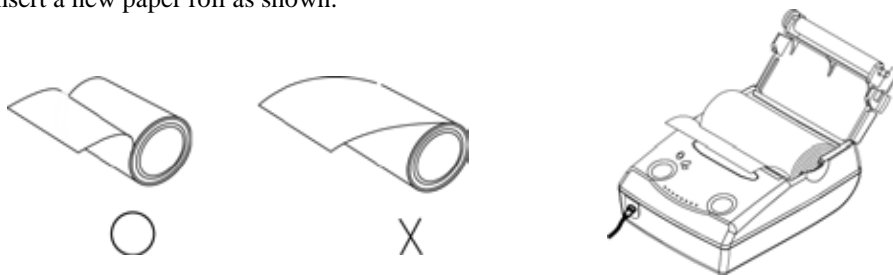

4. Tear the excess paper off using the edge of paper door as a tear bar.

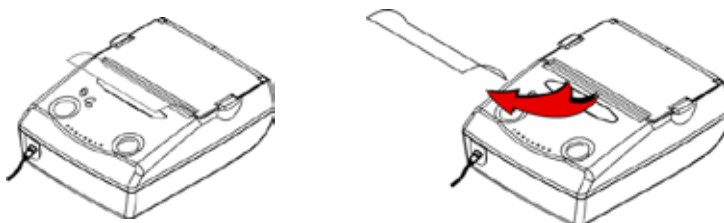

2.4. Power supply

The following specifications are requested for Power supply.

Input : DC 12V/ Max 3A

Avoid using power supply which its power capacity of power current is extremely high.

3. Interface

3.1. Serial

The Porti-ST30 printer has a UART(RS-232C or TTL) or RS-485 interface is connected by means of a 9 pin D-sub (Female Type)connector.

In the following table, the signals present on the connector are listed:

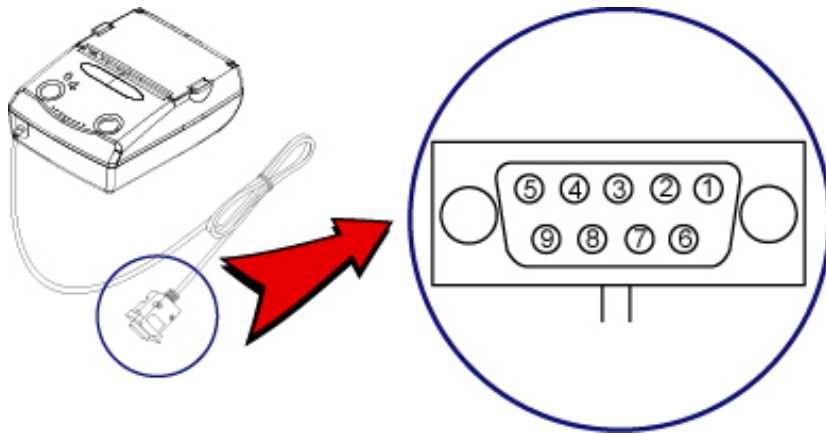

Pin No.	Signal Name	Direction	Function
2	TxD	Output	Transmit Data
3	RxD	Input	Receive Data
5	GND		Ground
9	Input Voltage		12VDC / 3A

<D-Sub 9p Female >

4. Using the printer

4.1. Control panel

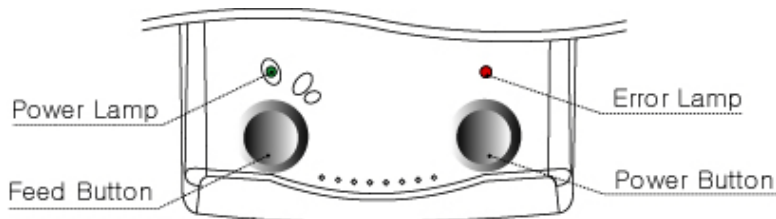

⌋ Button

- **FEED Button** : When the printer is on, paper can be feed manually by pressing and holding the FEED button for more than one second.

- **POWER Button** : Press the power button when turning on /off.

Function of the printer it stops but the power is perfect and it does not intercept.

(The electric current is consumed in the normality)

⌋ Panel lamp

- **Power(Green)** : Printer is ON and ready to receive data.

- **Error (Red)** : Indicates a fault condition or a printer error.

(i.e : no paper, paper cover opened. etc.)

4.2. The self test

The self test procedure will check most of the printer functions. For self test, turn on the power while holding down the FEED Button. The Self-Test checks the following :

- 1) Make sure paper roll has been installed properly.
- 2) The Self-Test prints the current printer status, which provides the control ROM version and the communication method setting.
- 3) After printing the current printer status, Self-Test will print a pattern using the built-in character set.
- 4) The Self-Test automatically ends.

The printer is ready to receive data as soon as it completed the self test.

5. Consumable Parts

5.1. Recommended paper

Type	: Thermal Paper
Paper width	: 57mm
Paper thickness	: $60 \pm 5 \mu\text{m}$
Outer diameter	: $\varnothing 30\text{mm}$ or less
Recording side	: Outside of roll



Cautions

1. Do not paste the paper to the core. And the roll paper which has near end mark printing on its near end is recommended.
2. Chemicals or oil may change the color of paper, or printed characters may fade.
3. Change of paper color starts from approx. 70°C .
Pay attention to heat, humidity and sun light.
4. Color of paper may be changed by being scratched by nail or hard metal, etc.

5.2. Printing position

