

**MODEL** **PORTI-SP**

**(Panel Printer)**

**Rev. 2.0**

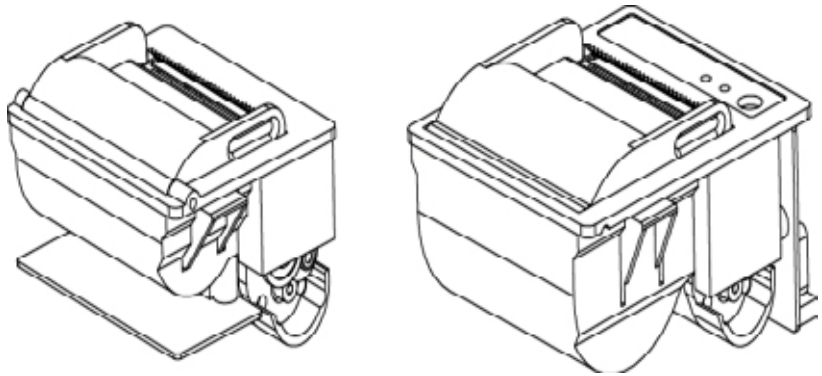

**WOOSIM SYSTEMS Inc.**

**#501, Daerung Technotown 3th,  
448, Gasan-Dong, GeumChun-Ku,  
Seoul, Korea**

**Tel : +82-2-2107-3700**

**Fax : +82-2-2107-3707**

**URL: <http://www.woosim.com>**

All specifications are subjected to change without notice

## ! Copyright

**PORTI-SP** 1inch panel printer operator's manual.

Copyright 2007 by Woosim Systems Inc.

All rights reserved.

The information contained in this manual is the property of Woosim Systems Inc. and may not be reproduced in whole or in part without the prior written permission of Woosim Systems Inc.

## ! Trademark



a registered trademark of Woosim Systems Inc.

All other trademark are the properties of their respective companies.

## ! Caution

Some semiconductor devices are easily damaged by static electricity. You should turn the printer "OFF", before you connect or removed the cable on the rear side, in order to guard the printer against the static electricity.

If the printer is damaged by the static electricity, you should turn the printer "OFF"

## ! Notice

The contents of this manual are subject to change without notice.

## 1 Introduction

The **PORTI-SP** is an extremely simple and functional panel printer. It is the ideal solution for applications which require the immediate printing of data on a paper, whether they be of an industrial, professional or laboratory nature.

Medical analyzer, Industrial instrument, Recorder, Geological analyzer, Underground analyzer, Chemical analyzer, Metallic analyzer, etc.

The general features of PORTI-SP printer are as follows:

- U Ultra small size rack mount printer.
- U Very silent printing thru direct thermal printing method.
- U High speed(50mm/sec, MAX)
- U High resolution(203dpi : 8dots/mm).
- U Easier paper loading by CLAMSHELL design.
- U Support text and graphic printing.
- U UART(RS-232C or TTL) interface
- U Easier maintenance with self-diagnostics.
- U In field programming – Update Firmware, Download Fonts and Logos
- U Flow control : Software (XON/XOFF)  
Hardware flow control not supported in printer.
- U Agency Approvals



## ! Operating Precautions

Please follow the precautions below to enjoy and maintain the full performance of the printer.

### U Using the Printer

- Be careful not to drop or bump the printer on a hard surface.
- Do not install the printer in direct sunlight or such areas.

Suitable environment for the use of the printer is as follows:

Operating temperature :-10°C to 50°C

Relative humidity : 10% to 90% (No condensation)

- Do not install the printer near devices that generate strong electromagnetic fields such as a copy machine.
- Do not open the platen cover during printing .
- Do not remove or reinstall the communication cable during printing or transmission.
- Do not touch the connectors of the communication during printing.
- Switch the POWER OFF when not in use.
- Do not use alcohol or other solvent.
- The AC adapter, the battery charger and the battery pack may become warm when in use. This is normal and is not a malfunction.
- When the battery pack is used at low temperature, the length of time the printer can be used may be shortened.

### U Thermal Paper Handling

- Store the thermal paper in a cool, dry and dark place.
- Do not rub the paper with hard object.
- Do not leave the paper with hard object.
- Do not allow plastic film, erasers, or adhesive tape to touch the paper for long periods.
- Do not stack the thermal paper with diazo copies immediately after copying or wet-type copies.
- Do not use chemical glue.
- Always use the clean thermal paper.

**| Note**

This equipment has been tested and found to comply with the limits for a Class B digital device, pursuant to Part 15 the FCC Rules.

These limits are designed to provide reasonable protection against harmful interference in a residential installation.

This equipment generates, uses and can radiate radio frequency energy and, if not installed and used in accordance with the instructions, may cause harmful interference to radio communications.

However, there is no guarantee that interference will not occur in a particular installation.

If this equipment does cause harmful interference to radio or television reception, which can be determined by turning the equipment off and on, the user is encouraged to try to correct the interference by one or more of the following measures:

- Reorient or relocate the receiving antenna.
- Increase the separation between the equipment and receiver.
- Connect the equipment into an outlet on a circuit different from that to which the receiver is connected.
- Consult the dealer or an experienced radio/TV technician for help.

# CONTENTS

- 1. Outline .....7**
  - 1.1. Model classifications.....7
  - 1.2. Product Part Number System .....7
  - 1.3. Specifications .....8
- 2. Setting up the printer .....9**
  - 2.1. Printer & Accessories.....9
  - 2.2. Printer Features ..... 10
    - 2.2.1. Porti-SP20 ..... 10
    - 2.2.2. Porti-SP30 ..... 10
  - 2.3. Installation..... 11
    - 2.3.1. Porti-SP20 ..... 11
    - 2.3.2. Porti-SP30 ..... 12
  - 2.4. Replacing the paper roll ..... 13
  - 2.5. Specified Power supply ..... 15
- 3. Interface.....16**
  - 3.1. Serial Interface ..... 16
- 4. Using the printer .....17**
  - 4.1. Control panel..... 17
  - 4.2. The self test ..... 18
- 5. Consumable Parts .....19**
  - 5.1. Recommended paper ..... 19
  - 5.2. Printing position ..... 20

# 1. Outline

## 1.1. Model classifications

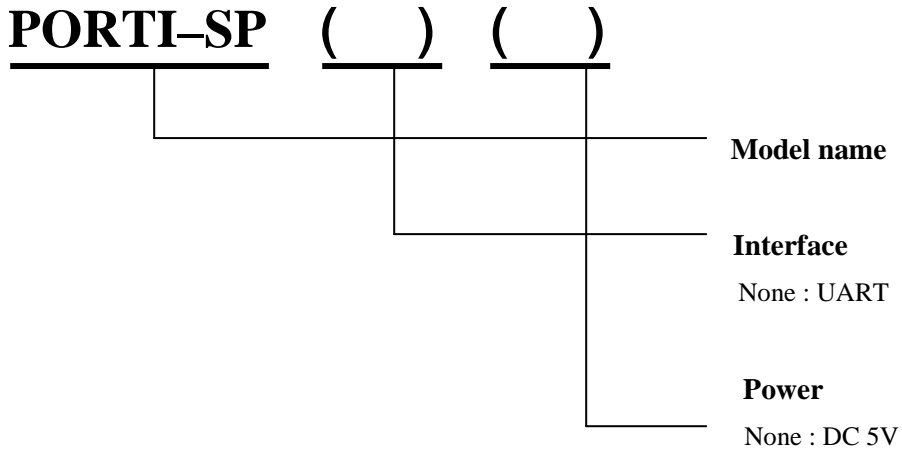

## 1.2. Product Part Number System

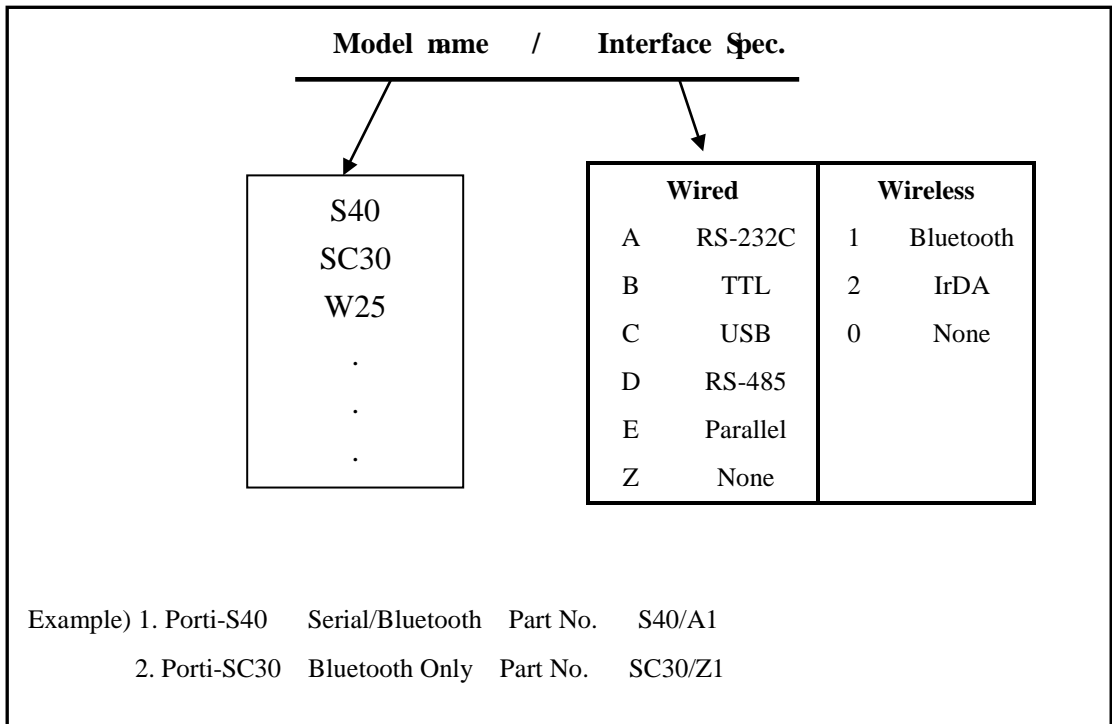

### 1.3. Specifications

Item	Specification	
Printing method	Direct thermal line printing	
Characters per line	24cpl (MAX)	
Character size	8 * 16dots, 9 * 24dots (Korean characters)	
Optional Characters	Simplified/Traditional Chinese, Arabic, Cyrillic, Russian, Turkish, Greek, Japanese, Persian, Latin9 and Others upon request.	
Resolution	203dpi, 8dots/mm	
Print width	1-inch (24mm, 192dots)	
Printing speed	50mm/sec (MAX)	
Dimensions	SP20 : 53 * 44.2 * 24.4 mm SP30 : 53 * 62 * 33.8 mm	
Weight	SP20 : 47g (including roll paper) SP30 : 51.5g (including roll paper)	
Interface	UART(RS-232C or TTL)	
Paper supplied	Thermal roll paper (37mm wide: 20ø, 30ø)	
Barcode supplied	1-dimension : Code128, Code39, I2/5, Code93 UPC, EAN, KAN, JAN, CODABAR 2-dimension : PDF417	
Receive buffer size	10K bytes	
Input Power	5VDC, Standby 60mA and Max 2.5A	
Environment conditions	Temperature	-10°C ~ 50°C (operating) -10°C ~ 70°C (storage)
	Humidity	30% - 80% (operating) 10% - 90% (storage)
MCBF	Mechanical	37,000,000 lines
	Head	Approximately 50 Km

< Table 1 >

## 2. Setting up the printer

### 2.1. Printer & Accessories

When unpacking your printer box make sure it contains the printer and all accessories.  
If any accessories are missing or damage, please contact your dealer for assistance.

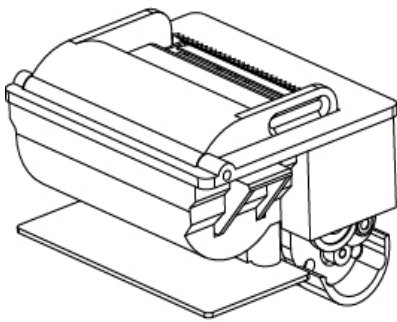

**PORTI-SP20**

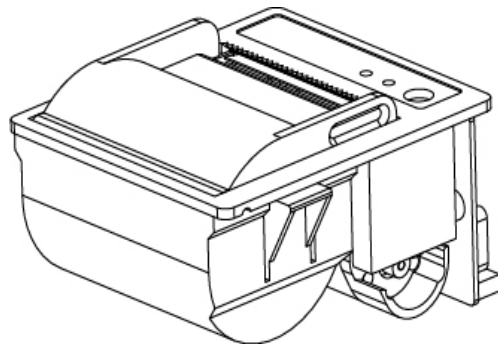

**PORTI-SP30**

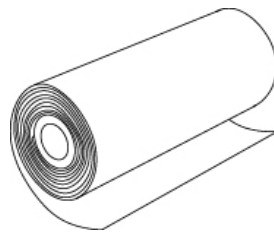

**Thermal roll paper**

## 2.2. Printer Features

### 2.2.1. Porti-SP20

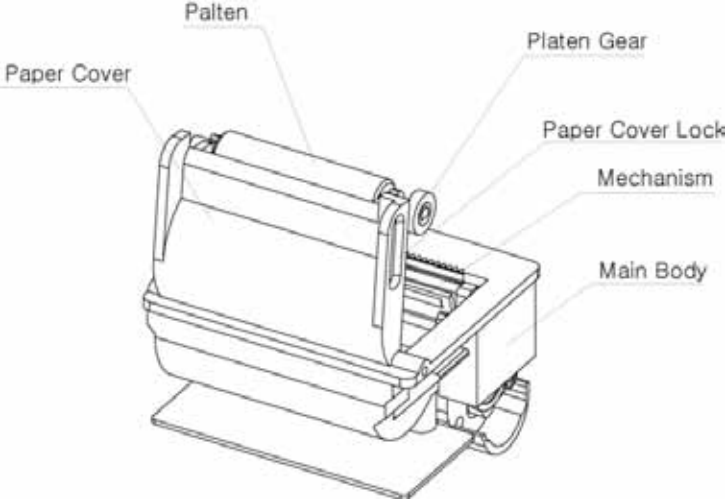

### 2.2.2. Porti-SP30

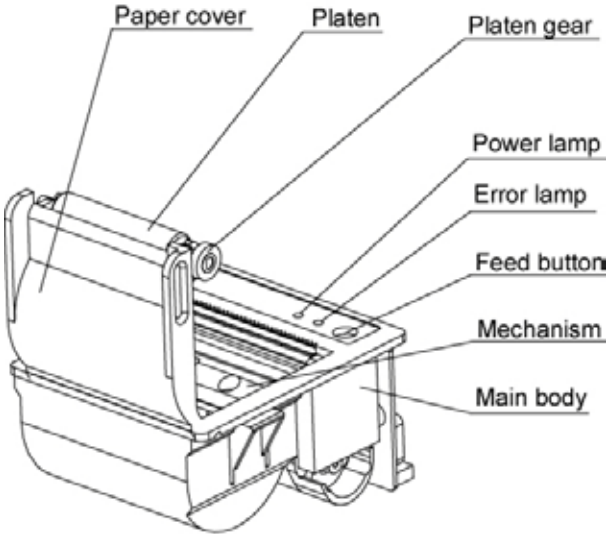

## 2.3. Installation

### 2.3.1. Porti-SP20

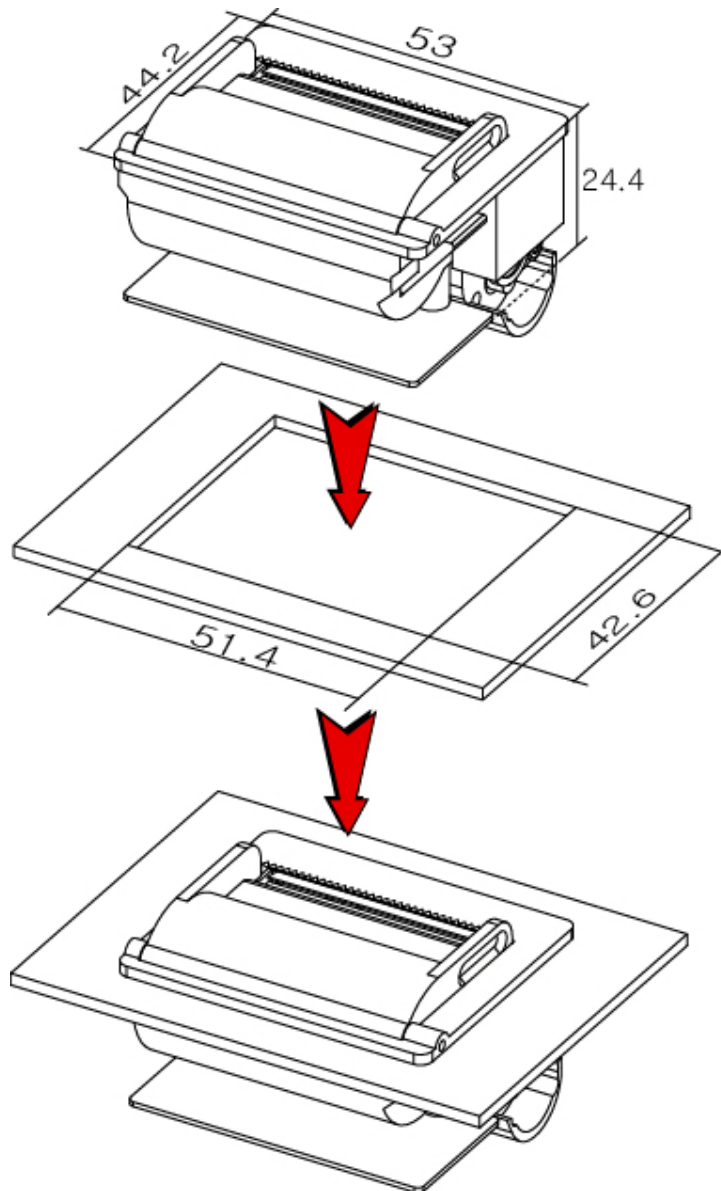

### 2.3.2. Porti-SP30

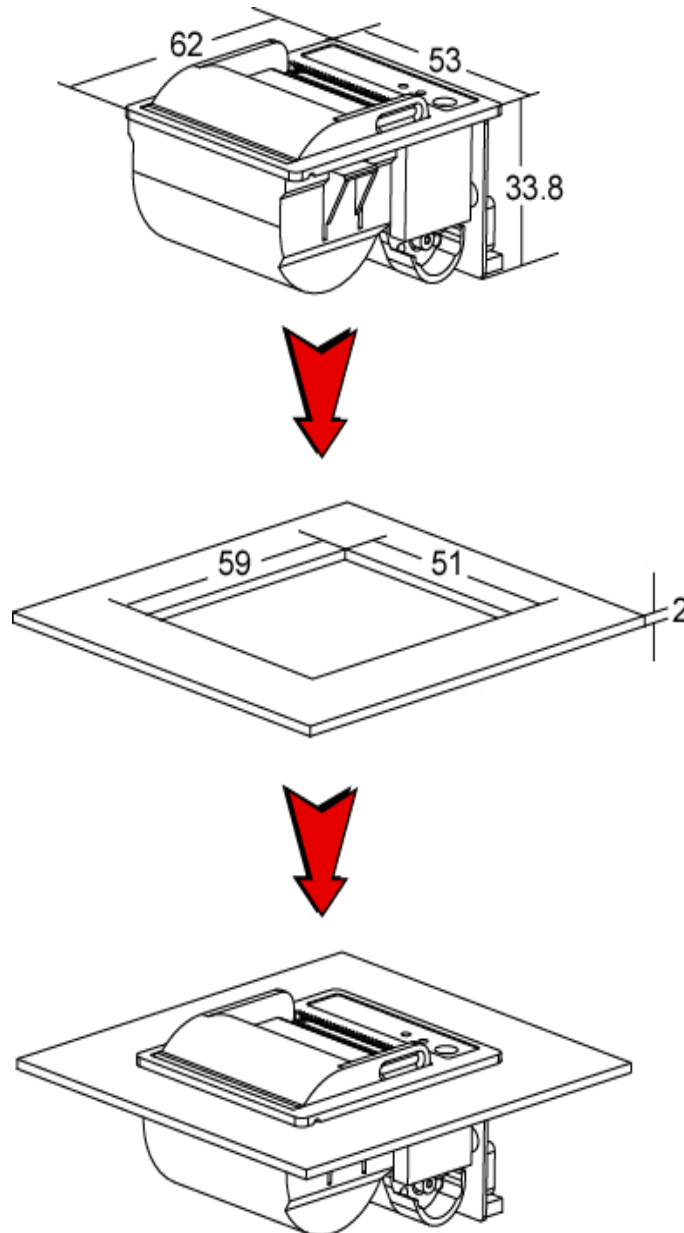

## 2.4. Replacing the paper roll

Note : Be sure to use paper rolls that meet the specifications.

Do not use paper rolls that have the paper glued to the core because the printer can not detect the paper end correctly.

1. Make sure that the printer is not receiving data; otherwise, data may be lost.
2. Open the paper roll cover by applying your finger on both side of printer, push it up when the lock is released as shown in the drawing.

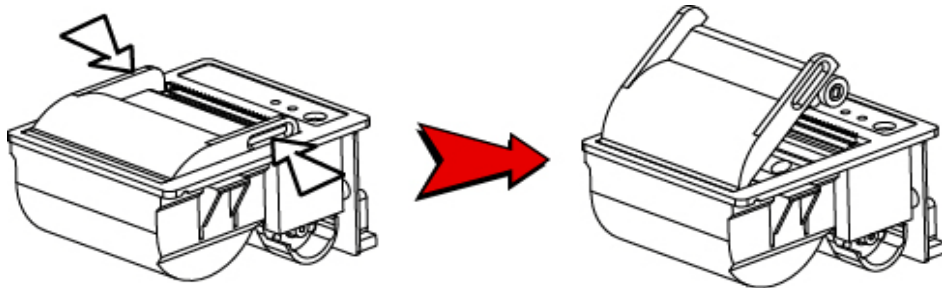

3. Remove the used paper roll core if there is one.
4. Insert the paper roll as shown.

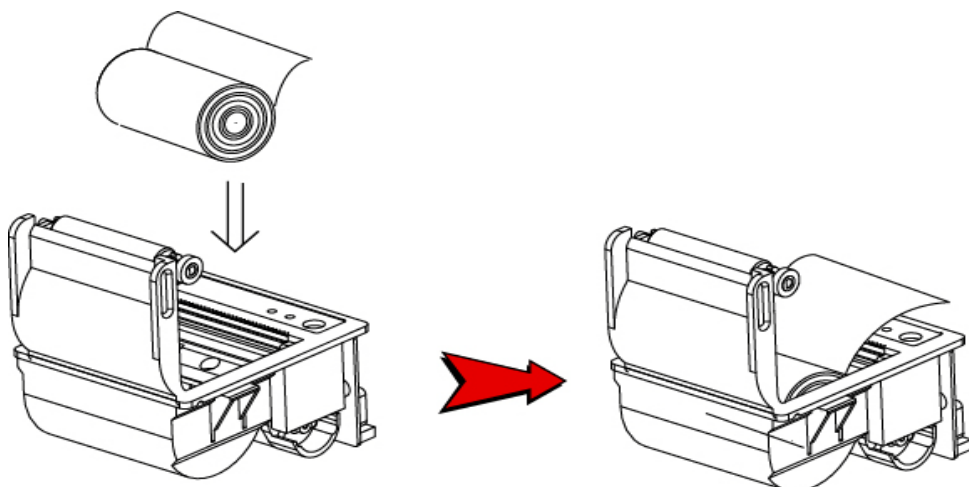

5. Be sure to note the correct direction that the paper comes off the roll.

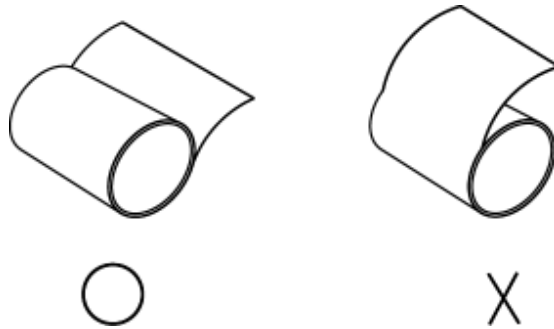

6. Pull out a small amount of paper and then close the cover as shown.

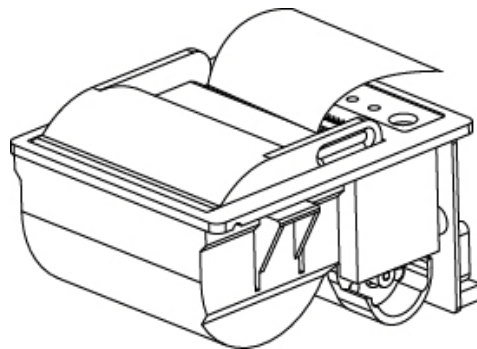

7. Tear off the paper as shown.

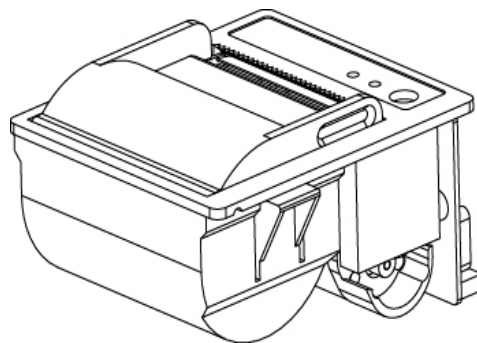

## **2.5. Specified Power supply**

The following specifications are requested for Power supply.

Input : DC 5V / Max 2.5A

Avoid using power supply which its power capacity of power current is extremely high.

## 3. Interface

### 3.1. Serial Interface

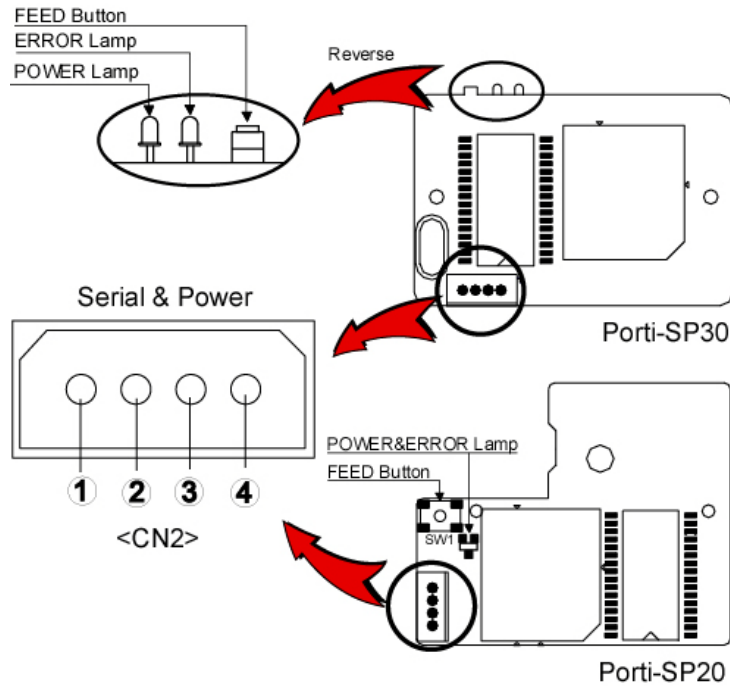

The Porti-SP(20 and 30) printer has an UART(RS-232C or TTL) serial interface and power connector is connected by 4 pin female connector.

In the following table, the signals present on the connector are listed:

Pin no	Signal name	Direction	Function
1	INPUT	-	5VDC/2.5A
2	TxD	Output	Transmit Data
3	RxD	Input	Receive Data
4	GND	-	Ground

<CN2 : MOLEX (53014-0410)>

Applicable connector : MOLEX 51004-0410 or equivalent.



#### WARNING

A wrong connection of power supply connector could be damage the printer

## 4. Using the printer

### 4.1. Control panel

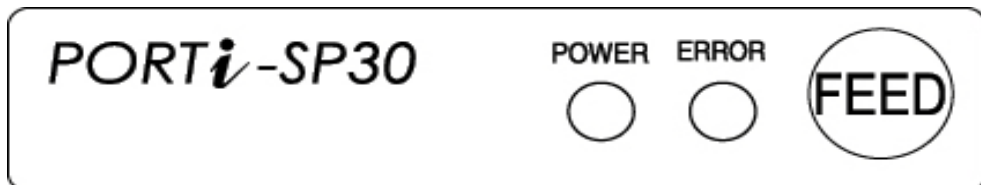

#### □ Button

- **FEED** : When the printer is on, paper can be feed manually by pressing and holding the FEED button for more than one second.

#### □ Panel lamp

- **Power(Green)** : Printer is ON and ready to receive data.
- **Error (Red)** : Indicates a fault condition or a printer error.  
(i.e : no paper, paper cover opened. etc.)

## **4.2. The self test**

The self test procedure will check most of the printer functions. For self test, turn on the power while holding down the FEED Button. The Self-Test checks the following :

- 1) Make sure paper roll has been installed properly.
- 2) The Self-Test prints the current printer status, which provides the control ROM version and the communication method setting.
- 3) After printing the current printer status, Self-Test will print a pattern using the built-in character set.
- 4) The Self-Test automatically ends.

The printer is ready to receive data as soon as it completed the self test.

## 5. Consumable Parts

### 5.1. Recommended paper

Type	: Thermal Paper
Paper width	: 37mm
Paper thickness	: $70 \pm 5 \mu\text{m}$
Outer diameter	: $\varnothing 20\text{mm}$ (SP20) or $\varnothing 30\text{mm}$ (SP30)
Recording side	: Outside of roll



#### Cautions

1. Do not paste the paper to the core. And the roll paper which has Near end mark printing on its near end is recommended.
2. Chemicals or oil may change the color of paper, or printed Characters may fade.
3. Change of paper color starts from approx 70 .  
Pay attention to heat, humidity and sun light.
4. Color of paper may be changed by being scratched by nail or hard metal, etc

### 5.2. Printing position

