

# Operator's Manual

**MODEL**    **PORTI-S30/40**

**(2inch Mobile Printer)**

**Rev. 3.0**

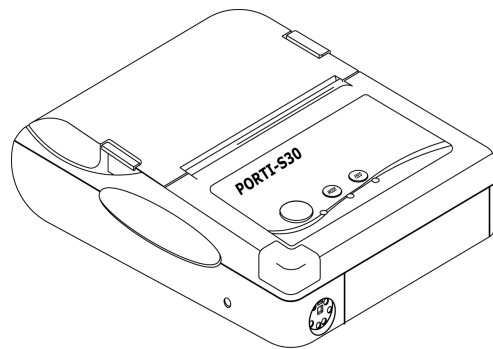

**WOOSIM SYSTEMS Inc.**

**#501, Daerung Technotown 3th,  
448, Gasan-Dong, GeumChun-Ku,  
Seoul, Korea**

**Tel : +82-2-2107-3700**

**Fax : +82-2-2107-3707**

**URL: <http://www.woosim.com>**

All specifications are subjected to change without notice

## **■ Copyright**

**PORTI-S30/40** 2inch mobile printer operator's manual.

Copyright ©2010 by Woosim Systems Inc.

All rights reserved.

The information contained in this manual is the property of Woosim Systems Inc.

And may not be reproduced in whole or in part without the prior written permission of Woosim Systems Inc.

## **■ Trademark**



a registered trademark of Woosim Systems Inc.

All other trademark are the properties of their respective companies.

## **■ Caution**

Some semiconductor devices are easily damaged by static electricity. You should turn the printer "OFF", before you connect or removed the cable on the rear side, in order to guard the printer against the static electricity.

If the printer is damaged by the static electricity, you should turn the printer "OFF".

## **■ Notice**

The contents of this manual are subject to change without notice.

## ■ Introduction

The **PORTI-S30/40** is suitable designed for use with a growing variety of mobile devices. IrDA/Serial or Bluetooth/Serial interfaces make the PORTI-S30/40 the perfect comrade for applications such as point of transaction warehousing, distribution, point of sales, hospitality, gaming and healthcare.

The general features of **PORTI-S30/40** printer are as follows:

- ▶ Pocket size (S30 : 75.95 x 103 x 36.15mm)
- ▶ Light weight (S30:226g, S40:264g) for true mobility.
- ▶ Very silent printing thru direct thermal printing method.
- ▶ High speed(80mm/sec, MAX)
- ▶ High resolution(203dpi : 8dots/mm).
- ▶ UART(RS-232C or TTL), Bluetooth Ver 2.1 + EDR  
IrDA Ver 1.0(SIR)[option], USB [option] Interface
- ▶ Intuitive LED's indicate Power(on/off),Error and Battery status
- ▶ Support text and graphic printing.
- ▶ Easier paper loading by CLAMSHELL design.
- ▶ Easier maintenance with self-diagnostics.
- ▶ In field programming – Update Firmware, Download Fonts and Logos
- ▶ Microsoft Windows XP / VISTA / 7 / CE / Linux / Android compatible.
- ▶ Free fall: 1.5 meter onto concrete
- ▶ Flow control : Software (XON/XOFF)  
※ Hardware flow control not supported in printer.
- ▶ Agency Approvals



## ■ Operating Precautions

Please follow the precautions below to enjoy and maintain the full performance of the printer.

### ▶ Using the Printer

- Be careful not to drop or bump the printer on a hard surface.
- Do not install the printer in direct sunlight or such areas.

Suitable environment for the use of the printer is as follows:

- ◆ Operating temperature : -10°C to 50°C
- ◆ Relative humidity : 30% to 80%
- Do not install the printer near devices that generate strong electromagnetic fields such as a copy machine.
- Do not open the platen cover during printing .
- Do not remove or reinstall the communication cable during printing or transmission.
- Do not touch the connectors of the communication during printing.
- Switch the POWER OFF when not in use.
- Do not use alcohol or other solvent.
- The AC adapter, the battery charger and the battery pack may become warm when in use. This is normal and is not a malfunction.
- When the battery pack is used at low temperature, the length of time the printer can be used may be shortened.

### ▶ Thermal Paper Handling

- Store the thermal paper in a cool, dry and dark place.
- Do not rub the paper with hard object.
- Do not leave the paper with hard object.
- Do not allow plastic film, erasers, or adhesive tape to touch the paper for long periods.
- Do not stack the thermal paper with diazo copies immediately after copying or wet-type copies.
- Do not use chemical glue.
- Always use the clean thermal paper.

**■ Note**

This equipment has been tested and found to comply with the limits for a Class B digital device, pursuant to Part 15 the FCC Rules.

These limits are designed to provide reasonable protection against harmful interference in a residential installation.

These equipment generates, uses and can radiate radio frequency energy and, if not installed and used in accordance with the instructions, may cause harmful interference to radio communications.

However, there is no guarantee that interference will not occur in a particular installation. If this equipment does cause harmful interference to radio or television reception , which can be determined by turning the equipment off and on, the user is encouraged to try to correct the interference by one or more of the following measures:

- Reorient or relocate the receiving antenna.
- Increase the separation between the equipment and receiver.
- Connect the equipment into an outlet on a circuit different from that to which the receiver is connected.
- Consult the dealer or an experienced radio/TV technician for help.

# CONTENTS

<b>1. Outline.....</b>	<b>7</b>
1.1. Model classifications.....	7
1.2. Product Part Number System.....	7
1.3. Specifications.....	8
<b>2. Setting up the printer.....</b>	<b>10</b>
2.1. Printer & Accessories.....	10
2.2. Printer Features.....	11
2.3. Replacing the paper roll.....	12
2.4. Power supply.....	13
2.4.1. Internal power supply.....	13
2.4.2. Installing the Battery.....	13
2.4.3. Recharging the battery.....	14
2.5. Set operation mode.....	15
<b>3. Interface.....</b>	<b>22</b>
3.1. UART(RS-232C or TTL) or USB.....	22
3.2. Infrared data communication.....	23
3.3. Bluetooth.....	24
<b>4. Using the printer.....</b>	<b>25</b>
4.1. Control panel.....	25
4.2. The self test.....	26
<b>5. Consumable Parts.....</b>	<b>27</b>
5.1. Recommended paper.....	27
5.2. Printing position.....	27

# 1. Outline

## 1.1. Model classifications

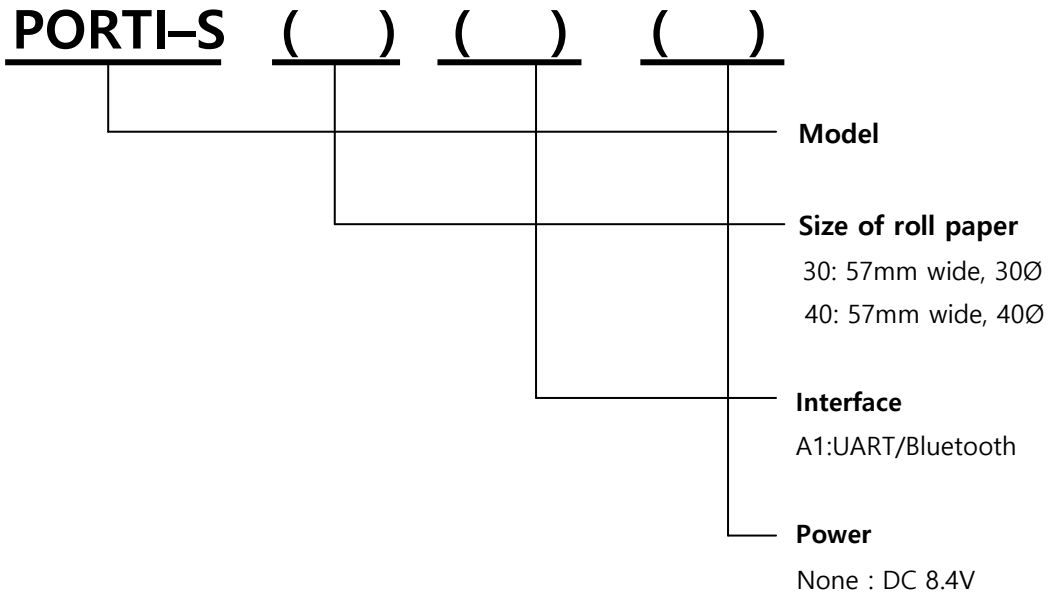

## 1.2. Product Part Number System

Model name	/	Interface Spec.																													
<div style="border: 1px solid black; padding: 5px; margin: 5px auto; width: 80%;">                     S40                      SC30                      W25                      ·                      ·                      ·                 </div>		<table border="1" style="width: 100%; border-collapse: collapse;"> <thead> <tr> <th colspan="2" style="text-align: left;">Wired</th> <th colspan="2" style="text-align: left;">Wireless</th> </tr> </thead> <tbody> <tr> <td style="width: 5%;">A</td> <td style="width: 40%;">RS-232C</td> <td style="width: 10%;">1</td> <td style="width: 45%;">Bluetooth</td> </tr> <tr> <td>B</td> <td>TTL</td> <td>2</td> <td>IrDA</td> </tr> <tr> <td>C</td> <td>USB</td> <td>0</td> <td>None</td> </tr> <tr> <td>D</td> <td>RS-485</td> <td></td> <td></td> </tr> <tr> <td>E</td> <td>Parallel</td> <td></td> <td></td> </tr> <tr> <td>Z</td> <td>None</td> <td></td> <td></td> </tr> </tbody> </table>	Wired		Wireless		A	RS-232C	1	Bluetooth	B	TTL	2	IrDA	C	USB	0	None	D	RS-485			E	Parallel			Z	None			
Wired		Wireless																													
A	RS-232C	1	Bluetooth																												
B	TTL	2	IrDA																												
C	USB	0	None																												
D	RS-485																														
E	Parallel																														
Z	None																														

Example) 1. Porti-S40    UART/Bluetooth    Part No. ⇒ S40/A1  
 2. Porti-SC30    Bluetooth Only    Part No. ⇒ SC30/Z1

Note) The above table is the interface format which is supported.  
 But some of the interfaces are not supported according to the product  
 and please contact us, if you have any questions regarding the interface.

### 1.3. Specifications.

Item	Specification
Printing method	Direct thermal line printing
Characters per line	42cpl (MAX)
Character size	Eng. : 9*24dots, 12*24dots    Kor. : 16*24dots, [24*24dots]
Optional Characters	Simplified/Traditional Chinese, Arabic, Cyrillic, Russian, Turkish, Greek, Japanese, Persian, Latin9 and Others upon request.
Resolution	203dpi, 8dots/mm
Print width	2-inch (48mm, 384dots)
Printing speed	80mm / sec (MAX)
Dimensions	S30 : 75.95 x 103 x 36.15 mm S40 : 75.95 x 103 x 44.75 mm
Weight	S30 : 226g,    S40 : 264g (Including battery & roll paper)
Interface	UART(RS-232C or TTL) , Bluetooth Ver2.1 + EDR IrDA Ver1.0(SIR) [option], USB[option]
Paper supplied	Thermal roll paper, Label roll (57mm wide, S30:30ø_S40:40ø)
Barcode supplied	1-dimension : Code128, Code39, I2/5, Code93 UPC, EAN, KAN, JAN, CODABAR 2-dimension : PDF417, QR Code, DATA Matrix
Driver	Microsoft Widows XP / VISTA / 7 Windows CE, Linux, Android OS driver compatible
Black mark	Support black mark detection
H/W spec.	MCU : 32bits RISC, FLASH : 4Mbytes, RAM : 8Mbytes
Receive buffer size	1M bytes
Battery	Rechargeable 7.4V DC , 1200mAh (Li-ion)
Battery duration	1 hour continuous printing
Battery Charger	Input (100~250V AC 50~60Hz) Output(8.4VDC/0.8A), 4hours full charge time

(Continue...)

Item	Specification	
<b>Environment Conditions</b>	Temperature	-10°C ~ 50°C (operating) -10°C ~ 70°C (storage)
	Humidity	30% - 80% (operating) 10% - 90% (storage)
<b>MCBF (Mean Cycle Between failure)</b>	Mechanical	37,000,000 lines
	Head	Approximately 50 Km

&lt; Table 1 &gt;

## 2. Setting up the printer

### 2.1. Printer & Accessories

Your printer box should include these items. If any items are damaged or missing, please contact your dealer for assistance.

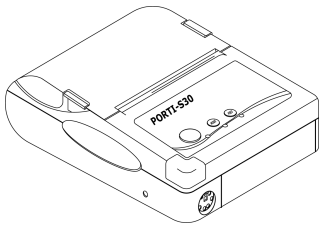

**PORTI-S**

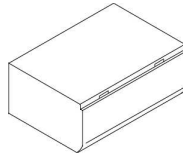

**Battery pack**

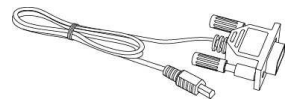

**Communication cable**

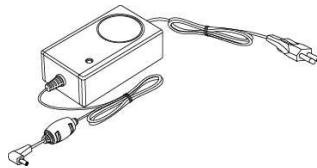

**Battery charger adaptor**



**Thermal roll paper**

#### ▼ OPTIONAL

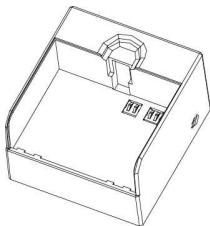

**External Battery Cradle**

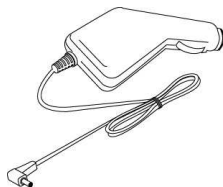

**Car charger**



**Leatherette case**

## 2.2. Printer Features

### ► Part Name

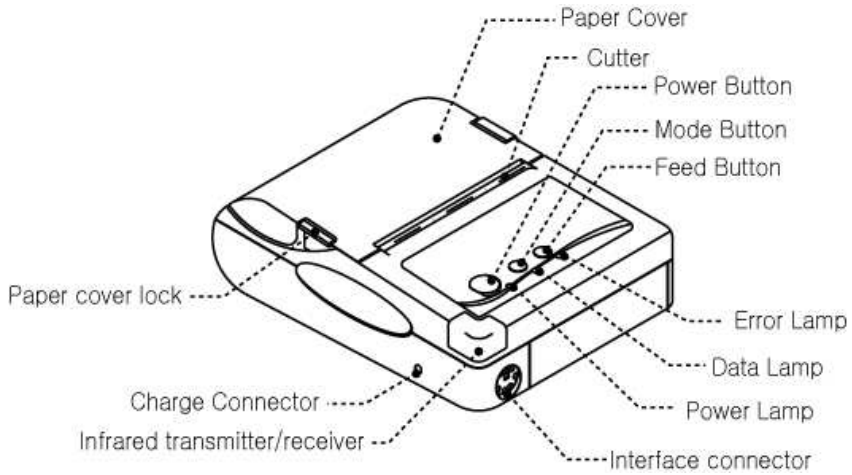

### ► Dimensions

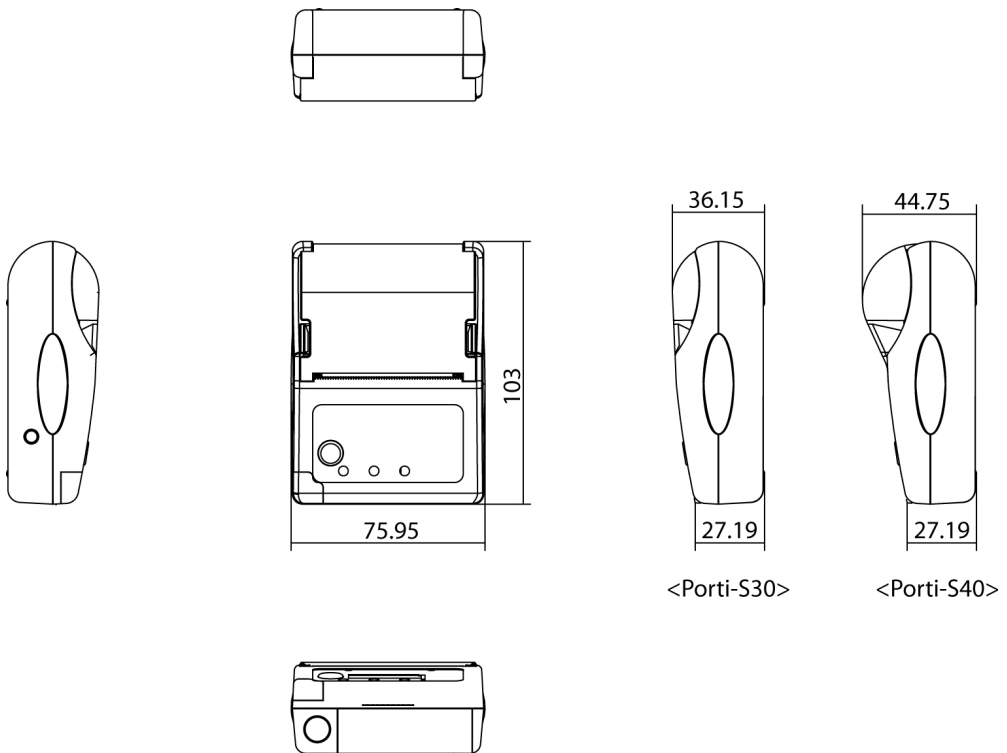

## 2.3. Replacing the paper roll

**Note :** Be sure to use paper rolls that meet the specifications.

Do not use paper rolls that have the paper glued to the core because the printer can not detect the paper end correctly.

1. Make sure that the printer is not receiving data; otherwise, data may be lost.
2. Open the paper cover using finger on both side of printer, and remove the remaining paper.

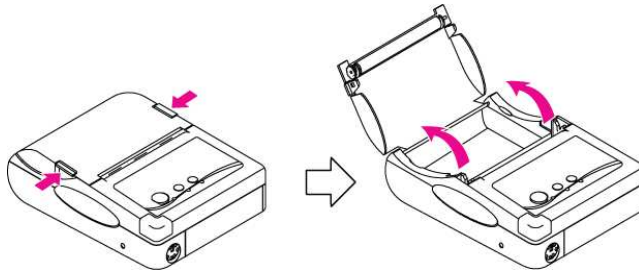

3. Insert the paper roll as shown.

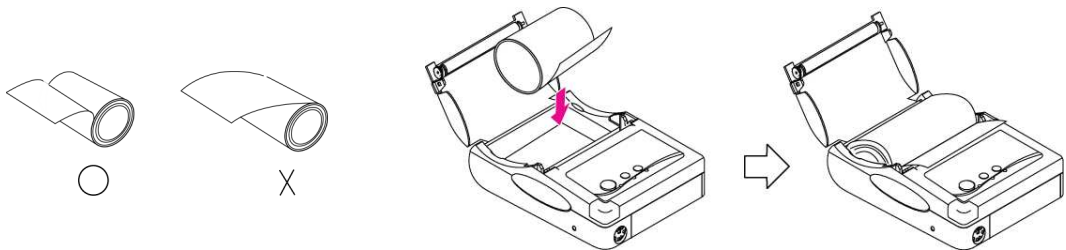

4. Tear the excess paper off using the edge of paper door as a tear bar.

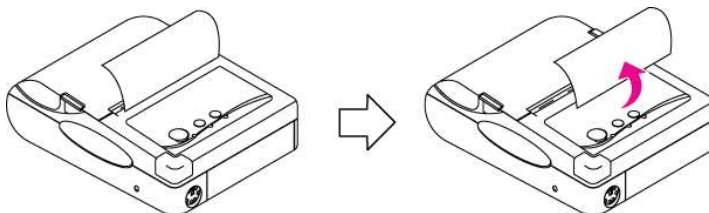

## 2.4. Power supply

### 2.4.1. Internal power supply

The following specification is requested for Power supply.

Battery Charger : DC 8.4V/0.8A

Avoid using power supply which its power capacity of power current is extremely high.

### 2.4.2. Installing the Battery

- NOTE :**
- Before installing or removing the battery pack, ensure the printer is OFF.
  - If the printer is not used for long period of time, remove the battery pack from the printer.

- ① To install battery pack, proceed as follows:
  - Insert the Battery pack in the direction of the arrow.

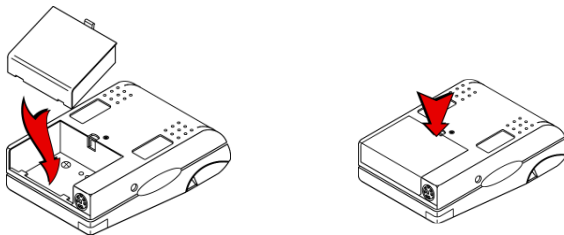

- ② To remove battery pack, proceed the above order reverse.

- ③ The battery pack install into External Battery Cradle.
  - Insert the Battery pack in the direction of the arrow.

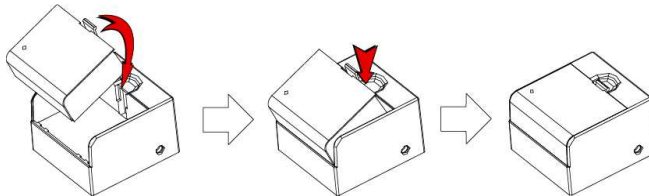

### 2.4.3. Recharging the battery

For recharging the battery pack, install the battery pack in the printer or the battery holder.

Insert the battery charger adaptor to the charge connector of the printer or the External Battery Cradle.

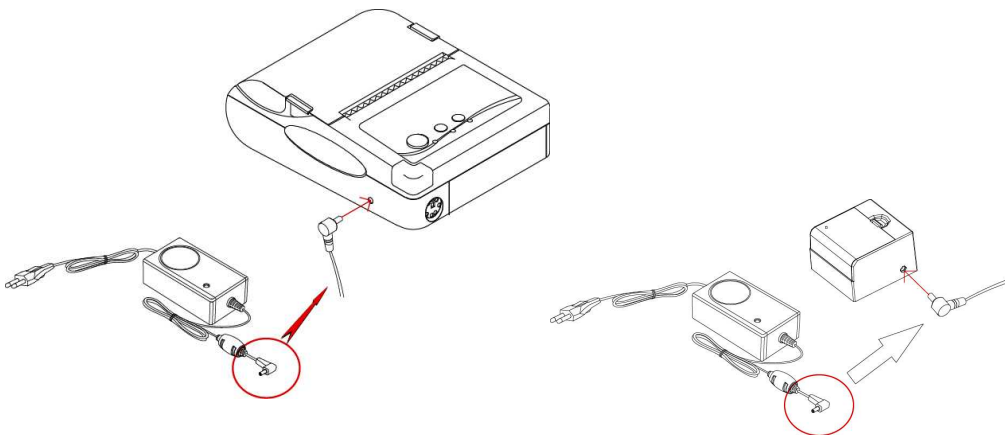

- NOTE :**
- While charging the printer, turn off the printer power.
  - Do not remove the battery during charging.
  - The battery is consumable parts and when purchasing, compared to the use hour is gradually decreases. (Warranty 6 month)
  - If the printer is not used for a long time, unplug the power cord from the printer and outlet.
  - The recharging time depends on the voltage level and ambient temperature of the battery. Normally, it takes about 4 to 5 hours to recharge a battery pack.
  - You must use only the supplied adaptor.
  - Red Lamp : charging the battery.  
Green Lamp: charging is finished.

## 2.5. Set operation mode

### < M37702 (OLD) Version >

Change the mode and option using the MODE Code.

- **MODE button** : use for changing OPTION status. (Error Lamp)
- **FEED button** : use for changing MODE status. (Power Lamp)

[Example] The defaults of the printer are :

RS-232C / 9600 bps / 8 data bit / No parity / Density low / Mark use / Sensor low

If a user wants to modify the defaults with

Bluetooth / 57600 bps / 7 data bit / Odd parity / Density high / Mark no use  
/ Sensor Medium1

- ▶ Press **MODE Button** during the **Error Lamp** flicking 5 times.
  - You will see the **Power Lamp** and the **Error Lamp** flickers once.
  - Press the **MODE Button** twice and the **Error Lamp** flickers 3 times.  
And then, interface mode has set to **Bluetooth** mode.
- ▶ When you press **FEED button** once again, **Power Lamp** flickers twice and the **Error Lamp** flickers 4 times.
  - Press **MODE Button** 3 times, **Error Lamp** flickers 7 times.  
And then, baudrate has set to **57,600 bps**.
- ▶ When you press **FEED Button** once again, **Power Lamp** flickers 3 times and the **Error Lamp** flickers twice.
  - Press **MODE Button** once, **Error Lamp** flickers once.  
And then Data Bit has set to **7 data bit**.
- ▶ When you press **FEED Button** once again, **Power Lamp** flickers 4 times and the **Error Lamp** flickers once.
  - Press **MODE Button** twice, **Error Lamp** flickers 3 times.  
And then the Parity bit has set to **Odd parity bit**.
- ▶ When you press **FEED Button** once again, **Power Lamp** flickers 5 times and **Error Lamp** flickers once.
  - Press **MODE Button** twice, **Error Lamp** flickers 3 times.  
And then the density has set to **Density high**.

- ▶ When you press **FEED Button** twice, **Power Lamp** flickers 7 times and **Error Lamp** flickers twice.  
→ Press **MODE Button** once, **Error Lamp** flickers twice.  
And then the mark has set to **Marm no use**.
- ▶ When you press **FEED Button** once again, **Power Lamp** flickers 8 times and **Error Lamp** flickers once.  
→ Press **MODE Button** once, **Error Lamp** flickers twice.  
And then the sensor has set to **Sensor medium1**.

If all the mode have set, press the **MODE Button** and the **FEED Button** at the same time after then release the buttons at the same time.

The printer will print out the mode status which has modified.

( **Bluetooth / 57,600 baud / 7 data bit / Odd parity / Density high / Mark no use/ Sensor Medium1** )

If the status is not correct, please try it again according to the procedure.

## \* M37702 ( OLD ) Version

MODE	POWER Lamp (Green)	ERROR Lamp (Red)	Option	
			IrDA	Bluetooth
Communication Port	1	1	RS-232C	RS-232C
		2	Protocol IrDA	Protocol Bluetooth
		3	Standard IrDA	Bluetooth
		4	Raw IrDA	-
Baud Rate	2	1	1200 bps	
		2	2400 bps	
		3	4800 bps	
		4	9600 bps	
		5	19200 bps	
		6	38400 bps	
		7	57600 bps	
		8	115200 bps	
Data Bit	3	1	7 Data bit	
		2	8 Data bit	
Parity Bit	4	1	No Parity	
		2	Even Parity	
		3	Odd Parity	
Density	5	1	Density Low	
		2	Density Medium	
		3	Density High	
Protocol	6	1	Default Protocol	
		2	Lotte Protocol	
Mark	7	1	No use	
		2	Use	
Sensor	8	1	Low	
		2	Medium1	
		3	Medium2	
		4	High	

## &lt; M16C, ARM ( NEW ) Version &gt;

Change the mode and option using the MODE Code.

- **MODE button** : use for changing OPTION status. (Error Lamp)
- **FEED button** : use for changing MODE status. (Power Lamp)

[Example] The defaults of the printer are :

RS-232C / 9600 bps / 8 data bit / No parity / 1 stop bit / Density low  
/ Mark use / Sensor low / Power down 5 minute

If a user wants to modify the defaults with

Bluetooth / 57600 bps / 7 data bit / Odd parity / 2 stop bit / Density high  
/ Mark no use / Sensor medium1 / Power down no use

- ▶ Press **MODE Button** during the **Error Lamp** flicking 5 times.  
→ You will see the **Power Lamp** and the **Error Lamp** flickers once.  
→ Press the **MODE Button** twice and the **Error Lamp** flickers 3 times.  
And then, interface mode has set to **Bluetooth** mode.
- ▶ When you press **FEED button** once again, **Power Lamp** flickers twice and the **Error Lamp** flickers once.  
→ Press **MODE Button** 3 times, **Error Lamp** flickers 4 times.  
And then, baudrate has set to **57,600 bps**.
- ▶ When you press **FEED Button** once again, **Power Lamp** flickers 3 times and the **Error Lamp** flickers twice.  
→ Press **MODE Button** once, **Error Lamp** flickers once.  
And then Data Bit has set to **7 data bit**.
- ▶ When you press **FEED Button** once again, **Power Lamp** flickers 4 times and the **Error Lamp** flickers once.  
→ Press **MODE Button** once, **Error Lamp** flickers twice.  
And then the Parity bit has set to **Odd parity bit**.
- ▶ When you press **FEED Button** once again, **Power Lamp** flickers 5 times and **Error Lamp** flickers once.  
→ Press **MODE Button** once, **Error Lamp** flickers twice.  
And then the density has set to **2 stop bit**.

- ▶ When you press **FEED Button** once again, **Power Lamp** flickers 6 times and **Error Lamp** flickers once.  
→ Press **MODE Button** twice, **Error Lamp** flickers 3 times.  
And then the density has set to **Density high**.
- ▶ When you press **FEED Button** once again, **Power Lamp** flickers 7 times and **Error Lamp** flickers twice.  
→ Press **MODE Button** once, **Error Lamp** flickers once  
And then the mark has set to **Mark no use**.
- ▶ When you press **FEED Button** once again, **Power Lamp** flickers 8 times and **Error Lamp** flickers once.  
→ Press **MODE Button** once, **Error Lamp** flickers twice  
And then the sensor has set to **Sensor medium1**.
- ▶ When you press **FEED Button** once again, **Power Lamp** flickers 9 times and **Error Lamp** flickers five times.  
→ Press **MODE Button** once, **Error Lamp** flickers once  
And then the power down has set to **Power down no use**.

If all the mode have set, press the **MODE Button** and the **FEED Button** at the same time after then release the buttons at the same time.

The printer will print out the mode status which has modified.

**(Bluetooth / 57600 bps / 7 data bit / Odd parity / 2 stop bit / Density high / Mark no use / Sensor medium1 / Power down no use)**

If the status is not correct, please try it again according to the procedure.

## \* M16C , ARM ( NEW ) Version

MODE	POWER Lamp (Green)	ERROR Lamp (Red)	Option	
			IrDA	Bluetooth
Communication Port	1	1	UART(RS-232C)	UART(RS-232C)
		2	Protocol UART(RS-232C)	Protocol UART (RS-232C)
		3	Raw IrDA	Bluetooth
		4	Protocol IrDA	Protocol Bluetooth
		5	Standard IrDA	-
Baud Rate	2	1	9600 bps	
		2	19200 bps	
		3	38400 bps	
		4	57600 bps	
		5	115200 bps	
Data Bit	3	1	7 Data bit	
		2	8 Data bit	
Parity	4	1	No Parity	
		2	Odd Parity	
		3	Even Parity	
Stop bit	5	1	1 stop bit	
		2	2 stop bit	
Density	6	1	Density Low	
		2	Density Medium	
		3	Density High	
Mark	7	1	No use	
		2	Use	
Sensor	8	1	Low	
		2	Medium1	
		3	Medium2	
		4	High	

(Continue...)

MODE	POWER Lamp (Green)	ERROR Lamp (Red)	Option
Power Down	9	1	No use
		2	1 minute
		3	2 minute
		4	3 minute
		5	4 minute
		6	5 minute

&lt; Table 3 &gt;

### 3. Interface

#### 3.1. UART(RS-232C or TTL) or USB

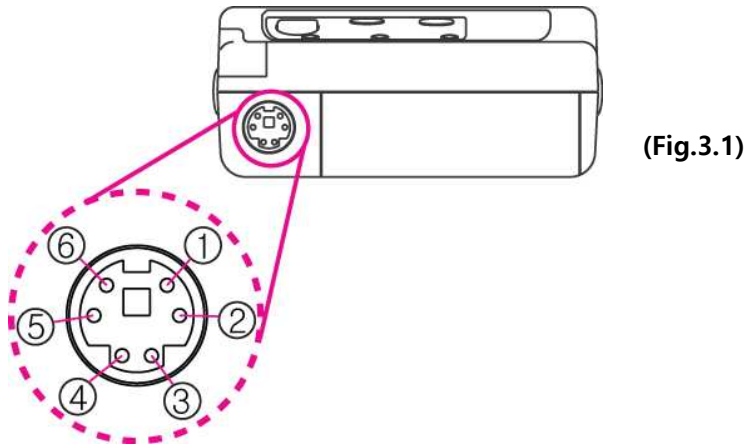

(Fig.3.1)

The PORTI-S printer has an UART(RS-232C or TTL) or USB interface are connected by means of a 6 pin male connector. In the following table, the signals present on the connector are listed:

① **UART(RS-232C)**

Pin no	Signal Name	Direction	Function
6	GND	-	Ground
5	N.C	-	-
4	N.C	-	-
3	RxD	Input	Receive data
2	N.C	-	-
1	TxD	Output	Transmit data

② **USB**

Pin no	Signal Name	Direction	Function
6	N.C		Ground
5	N.C		
4	GND		
3	DP		
2	VCC	-	5V
1	DM		

**NOTE :** ● When data receiving, when it removes the communication cable, it loses a data.

### 3.2. Infrared data communication

The PORTI-S has a serial interface for bi-directional data exchange. The infrared port is the upper edge part of the left side.

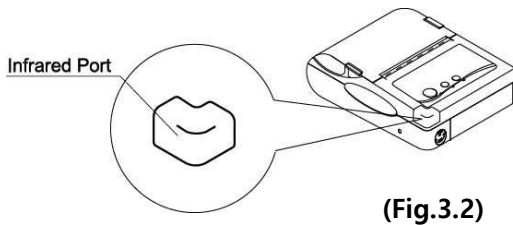

- 1) To use the PORTI-S's infrared port, a computer or Personal Digital Assistant (PDA) with IR port is required.
- 2) Position a PDA conforming to the specifications in point not more than 50 centimeter away from the printer's infrared port. Make sure the two ports are in front of each other with an angle of not more than 15° on the four sides (see fig.3.3)

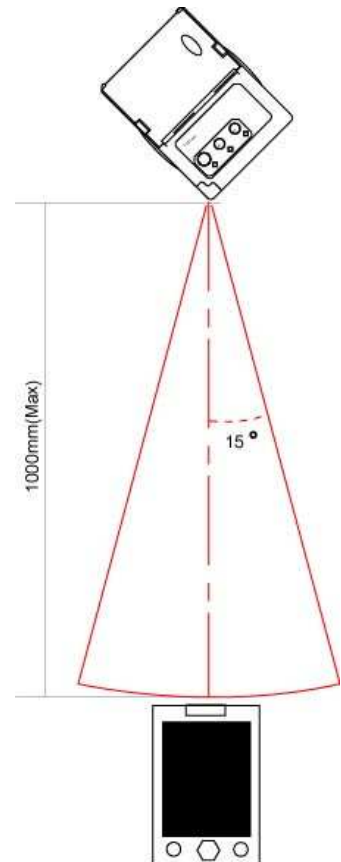

**NOTE :** ● When infrared ray communication doing, directness it does not see the IrDA window roll up.  
Eye damage there is a danger.

### 3.3. Bluetooth

Category	Specification
Bluetooth Spec.	Bluetooth Ver2.1 +EDR / Class2 (10m)
Frequency Range	2.4GHz ISM BAND
Data Transmission Rate	57600bps Fixed.
Data bit	8 Data bit Fixed.
Parity bit	No parity Fixed.
Stop bit	1 Stop bit Fixed.

## 4. Using the printer

### 4.1. Control panel

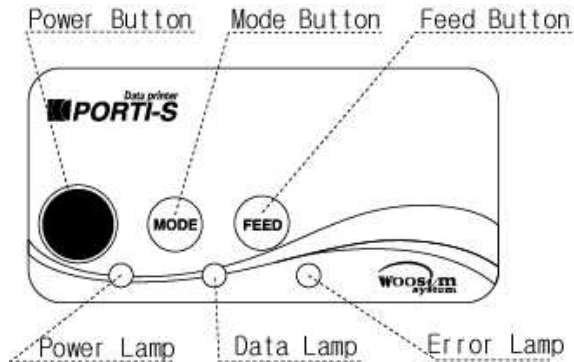

(Fig.4.1)

#### ► Button

##### FEED :

When the printer is on, paper can be feed manually by pressing and holding the FEED button for more than one second.

##### - MODE :

MODE Button is for use to change communication mode.

Do not operate the mode button without instructions.

#### ► Panel lamp

-**Power** : Printer is ON and ready to receive data.

The status indicator will flash continuously to show the batteries are nearly exhausted and in need of re-charging.

-**Error** : Indicates a fault condition or a printer error.

(i.e : no paper, paper cover opened. etc.)

-**Data** : The **Data lamp** is on whenever the printer receives data.

## **4.2. The self test**

The Self-Test checks whether the printer has any problems. If the printer does not function properly, contact your dealer. For Self-Test, turn on the power while holding down the FEED Button. The Self-Test checks the following :

- 1) Make sure paper roll has been installed properly.
- 2) The Self-Test prints the current printer status, which provides the control ROM version and the communication method setting.
- 3) After printing the current printer status, Self-Test will print a pattern using the built-in character set.
- 4) The Self-Test automatically ends.

The printer is ready to receive data as soon as it complete the Self-Test.

## 5. Consumable Parts

### 5.1. Recommended paper

Type	: Thermal Paper
Paper width	: 57mm
Paper thickness	: $60 \pm 5 \mu\text{m}$
Outer diameter	: $\varnothing 30\text{mm}$ or less (S30), $\varnothing 40\text{mm}$ or less (S40)
Recording side	: Outside of roll



#### Cautions

1. Do not paste the paper to the core, and the roll paper which has near end mark printing on its near end is recommended.
2. Chemicals or oil may change the color of paper, or printed characters may fade.
3. Change of paper color starts from approx. 70 °C.  
Pay attention to heat, humidity and sun light.
4. Color of paper may be changed by being scratched by nail or hard metal, etc.

### 5.2. Printing position

