

MODEL **PORTI-P**

(2Inch Panel Printer)

Rev. 5.0

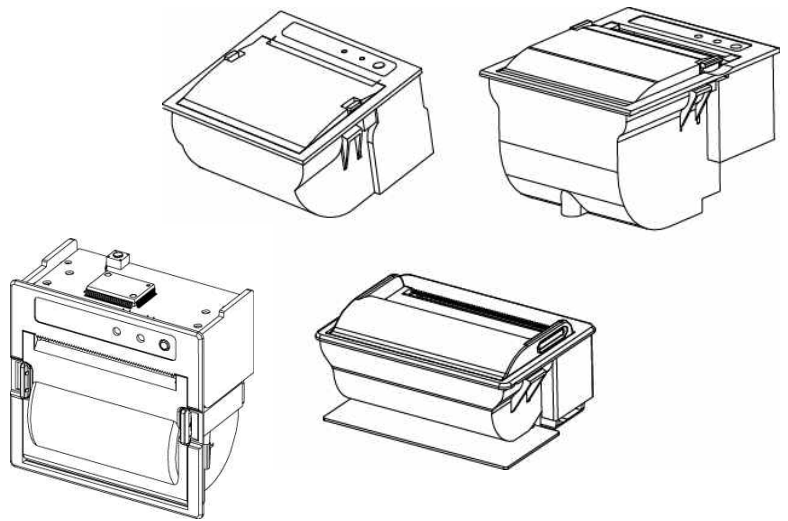

WOOSIM SYSTEMS Inc.

**#501, Daerung Technotown 3th, 448,
Gasan-Dong, GeumChun-Ku, Seoul,
Korea**

Tel : +82-2-2107-3700

Fax : +82-2-2107-3707

URL: <http://www.woosim.com>

All specifications are subjected to change without notice

■ Copyright

PORTI-P 2Inch Panel Printer Operator's Manual.

Copyright ©2012 by Woosim Systems Inc.

All rights reserved.

The information contained in this manual is the property of Woosim Systems Inc.

And may not be reproduced in whole or in part without the prior written permission of Woosim System Inc.

■ Trademark



a registered trademark of Woosim Systems Inc.

All other trademark are the properties of their respective companies.

■ Caution

Some semiconductor devices are easily damaged by static electricity. You should turn the printer "OFF", before you connect or removed the cable on the rear side, in order to guard the printer against the static electricity.

If the printer is damaged by the static electricity, you should turn the printer "OFF"

■ Notice

The contents of this manual are subject to change without notice.

■ Introduction

The **PORTI-P** is an extremely simple and functional panel printer. It is the ideal solution for applications which require the immediate printing of data on a paper, whether they be of an industrial, professional or laboratory nature.

Medical analyzer, Industrial instrument, Recorder, Geological analyzer, Underground analyzer, Chemical analyzer, Metallic analyzer, etc.

The general features of PORTI-P printer are as follows:

- ▶ Ultra small size rack mount printer.
- ▶ Very silent printing thru direct thermal printing method.
- ▶ High speed(50mm/sec, MAX)
- ▶ High resolution(203dpi : 8dots/mm).
- ▶ UART(RS-232C or TTL), Parallel(Porti-PP40, PP60 Only) interface
- ▶ Support text and graphic printing.
- ▶ Easier paper loading by CLAMSHELL design.
- ▶ Easier maintenance with self-diagnostics.
- ▶ In field programming – Update Firmware, Download Fonts and Logos
- ▶ Microsoft Windows XP / VISTA / 7 / CE / Linux / Android compatible.
- ▶ Flow control : Software (XON/XOFF)
 - ※ Hardware flow control not supported in printer.
- ▶ Agency Approvals



■ Operating Precautions

Please follow the precautions below to enjoy and maintain the full performance of the printer.

▶ Using the Printer

- Be careful not to drop or bump the printer on a hard surface.
- Do not install the printer in direct sunlight or such areas.

Suitable environment for the use of the printer is as follows:

- ◆ Operating temperature :-10°C to 50°C
- ◆ Relative humidity : 10% to 90% (No condensation)
- Do not install the printer near devices that generate strong electromagnetic fields such as a copy machine.
- Do not open the platen cover during printing .
- Do not remove or reinstall the communication cable during printing or transmission.
- Do not touch the connectors of the communication during printing.
- Switch the POWER OFF when not in use.
- Do not use alcohol or other solvent.

▶ Thermal Paper Handling

- Store the thermal paper in a cool, dry and dark place.
- Do not rub the paper with hard object.
- Do not leave the paper with hard object.
- Do not allow plastic film, erasers, or adhesive tape to touch the paper for long periods.
- Do not stack the thermal paper with diazo copies immediately after copying or wet-type copies.
- Do not use chemical glue.
- Always use the clean thermal paper.

■ Note

This equipment has been tested and found to comply with the limits for a Class B digital device, pursuant to Part 15 the FCC Rules.

These limits are designed to provide reasonable protection against harmful interference in a residential installation.

This equipment generates, uses and can radiate radio frequency energy and, if not installed and used in accordance with the instructions, may cause harmful interference to radio communications.

However, there is no guarantee that interference will not occur in a particular installation.

If this equipment does cause harmful interference to radio or television reception, which can be determined by turning the equipment off and on, the user is encouraged to try to correct the interference by one or more of the following measures:

- Reorient or relocate the receiving antenna.
- Increase the separation between the equipment and receiver.
- Connect the equipment into an outlet on a circuit different from that to which the receiver is connected.
- Consult the dealer or an experienced radio/TV technician for help.

CONTENTS

1. Outline	7
1.1. Model classifications	7
1.2. Product Part Number System.....	8
1.3. Specifications	9
2. Setting up the printer	11
2.1. Printer & Accessories	11
2.2. Printer Features.....	12
2.2.1. Porti-P30.....	12
2.2.2. Porti-P40 (include P240, PP40).....	13
2.2.3. Porti-P60.....	15
2.3. Installation	16
2.3.1. Porti-P30.....	16
2.3.2. Porti-P40 (include PP40).....	17
2.3.3. Porti-P240.....	18
2.3.4. Porti-P60.....	19
2.4. Replacing the paper roll.....	20
2.5. Setting operation mode	21
2.6. Power supply	27
3. Interface.....	28
3.1. Serial Interface (Porti-P30).....	28
3.2. Serial Interface (Porti-P40 /60, P240).....	29
3.3. Serial and Parallel Interface (Porti-PP40/60).....	30
4. Using the printer	33
4.1. Control panel	33
4.2. The self test.....	33
5. Consumable Parts.....	34
5.1. Recommended paper	34
5.2. Printing position	34
6. Revision History.....	35

1. Outline

1.1. Model classifications

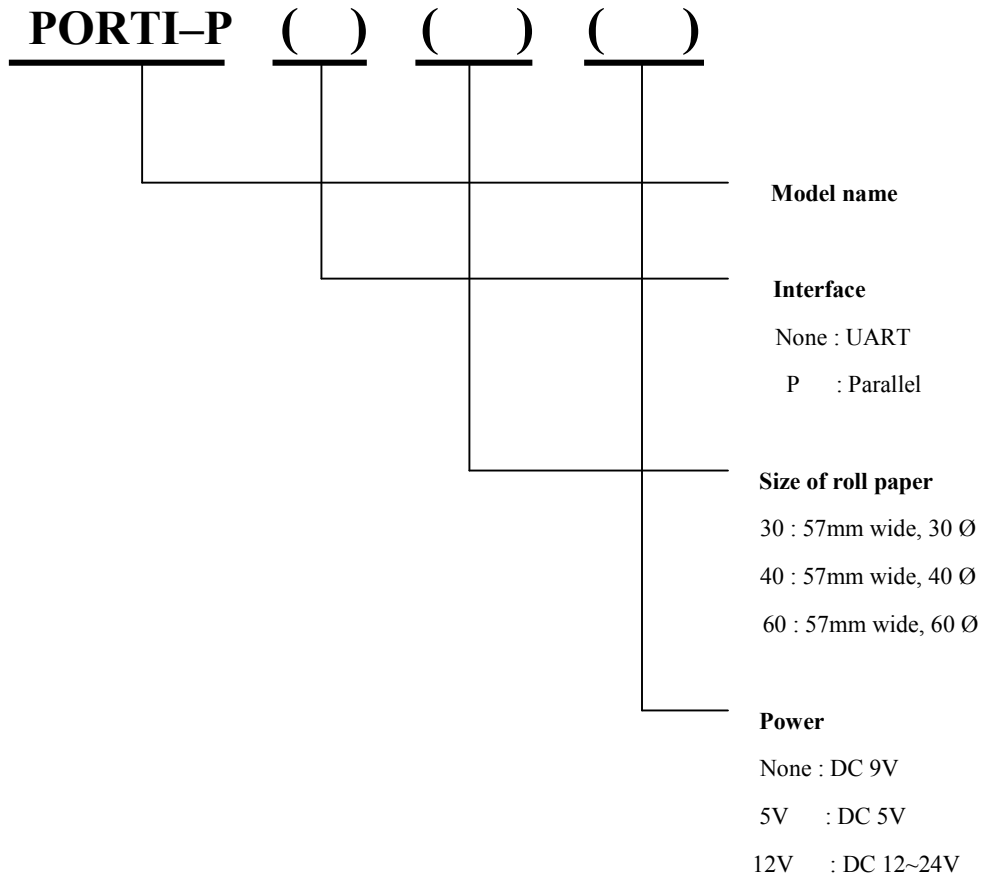

1.2. Product Part Number System

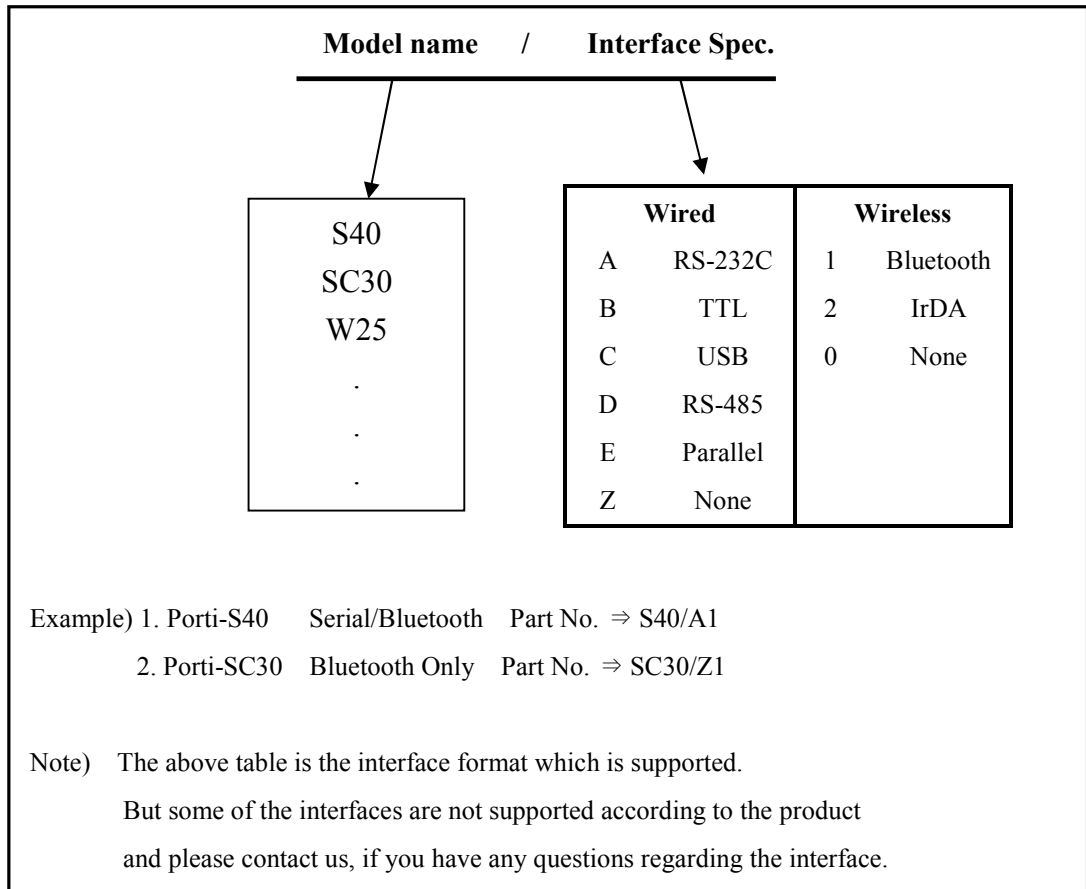

1.3. Specifications

Item	Specification
Printing method	Direct thermal line printing
Characters per line	42cpl (MAX)
Character size	Eng. : 9*24dots, 12*24dots Kor. : 16*24dots, [24*24dots]
Optional Characters	Simplified/Traditional Chinese, Arabic, Cyrillic, Russian, Turkish, Greek, Japanese, Persian, Latin9 and Others upon request.
Resolution	203dpi, 8dots/mm
Print width	2-inch (48mm, 384dots)
Printing speed	50mm/sec (MAX)
Dimensions (including PCB)	-P30 : 75 * 55 * 30.3 mm -P40,P240 : 80 * 75 * 40 mm -P60 : 76 * 93 * 62 mm -PP40 : 80 * 75 * 55 mm -PP60 : 76 * 93 * 62 mm
Weight (including roll paper)	-P30 : 102.5g -P40,P240 : 153g -P60 : 274g -PP40 : 164.5g -PP60 : 285.5g
Interface	UART(RS-232C or TTL) (P30,P40,P240,P60,PP40, PP60) Parallel (PP40, PP60 only)
Paper supplied	Thermal roll paper (57mm wide, 30ø 40ø, 60ø)
Barcode supplied	1-dimension : Code128, Code39, I2/5, Code93 UPC, EAN, KAN, JAN, CODABAR 2-dimension : PDF417, QR-Code, DATA Matrix
Driver	Microsoft Widows XP / VISTA / 7 Windows CE, Linux, Android OS driver compatible
Receive buffer size	10K bytes
Input Power	5VDC, Standby 60mA and Max 2.5A (P30, P40,P240) 9VDC, Standby 60mA and Max 3A (P30,P40,P240, P60) 12V~24VDC, Standby 60mA and Max 3A (PP40, PP60)

(Continue...)

Item	Specification	
Environment conditions	Temperature	-10°C ~50°C (operating) -10°C ~ 70°C (storage)
	Humidity	30% - 80% (operating) 10% - 90% (storage)
MCBF (Mean Cycle Between failure)	Mechanical	37,000,000 lines
	Head	Approximately 50 Km

< Table 1 >

2. Setting up the printer

2.1. Printer & Accessories

When unpacking your printer box make sure it contains the printer and all accessories.
If any accessories are missing or damage, please contact your dealer for assistance.

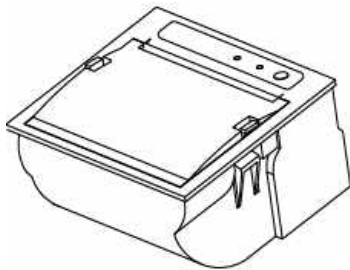

**Porti-P40,
PP40**

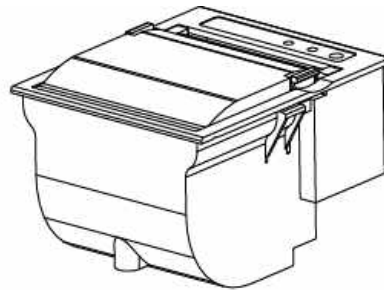

**Porti-P60,
PP60**

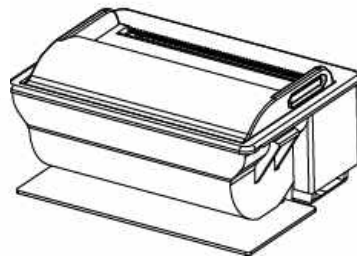

Porti-P30

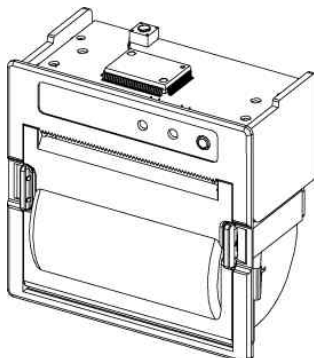

Porti-P240

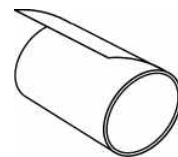

Thermal roll paper

2.2. Printer Features

2.2.1. Porti-P30

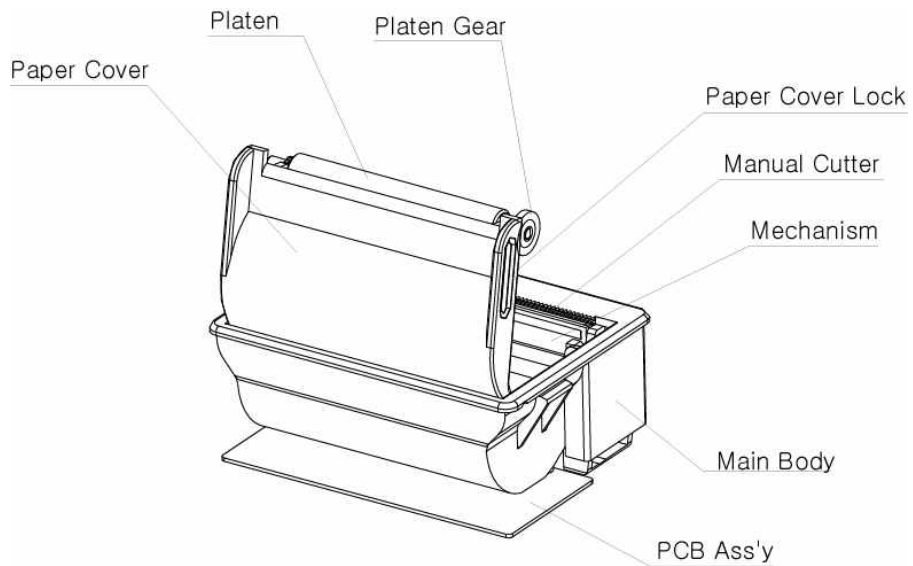

2.2.2. Porti-P40 (include P240, PP40)

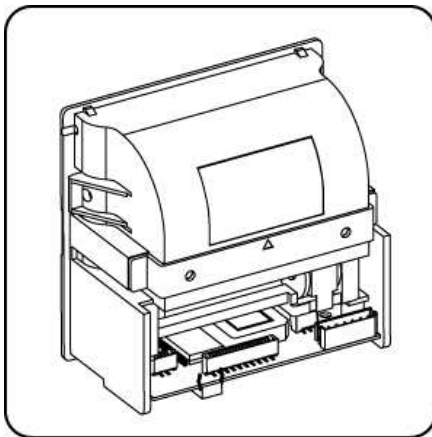
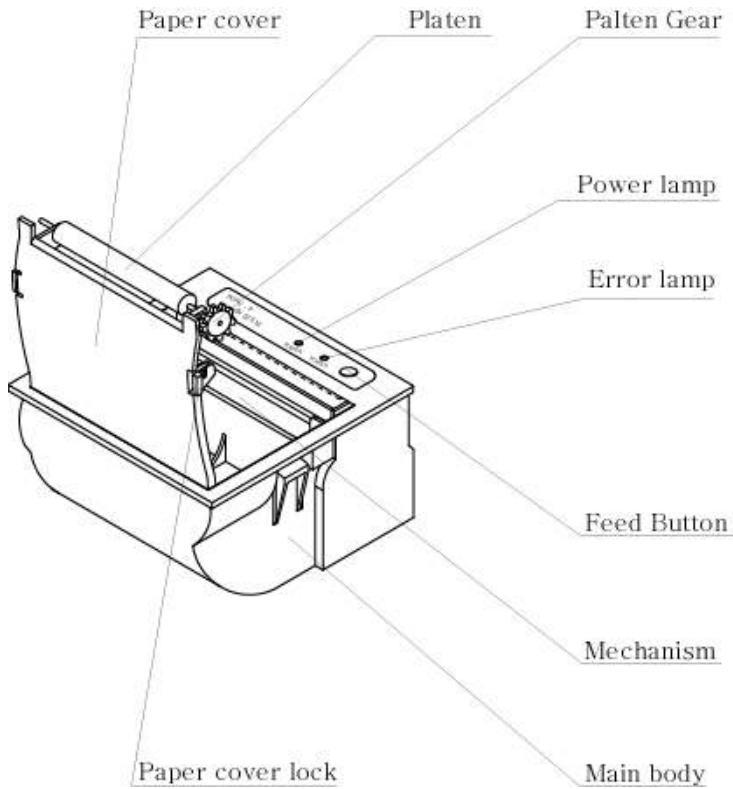

[P240]

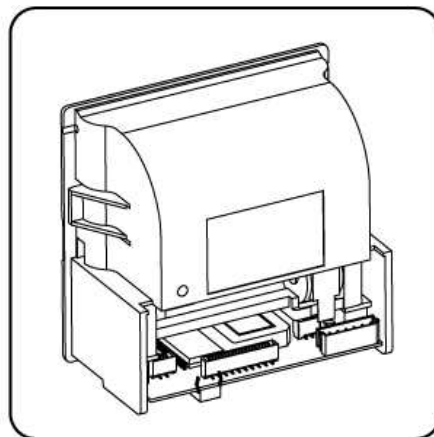

[P40]

** P240 Dimensions

[unit : mm]

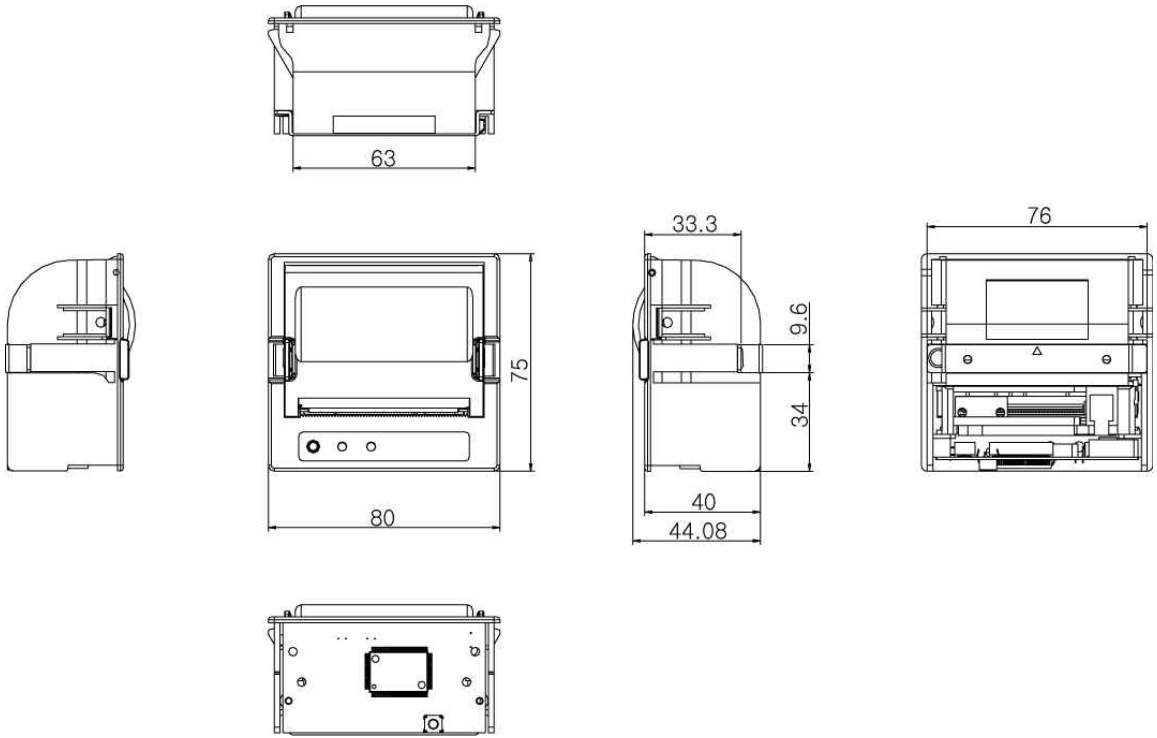

2.2.3. Porti-P60

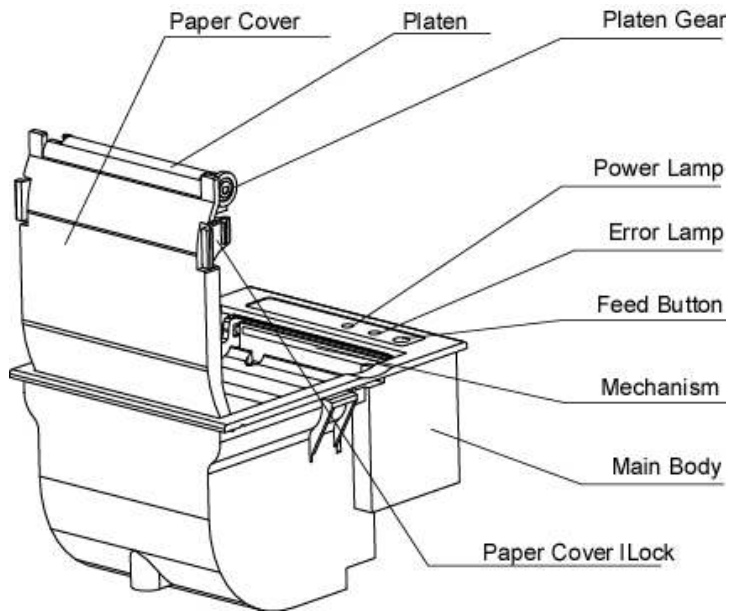

2.3. Installation

2.3.1. Porti-P30

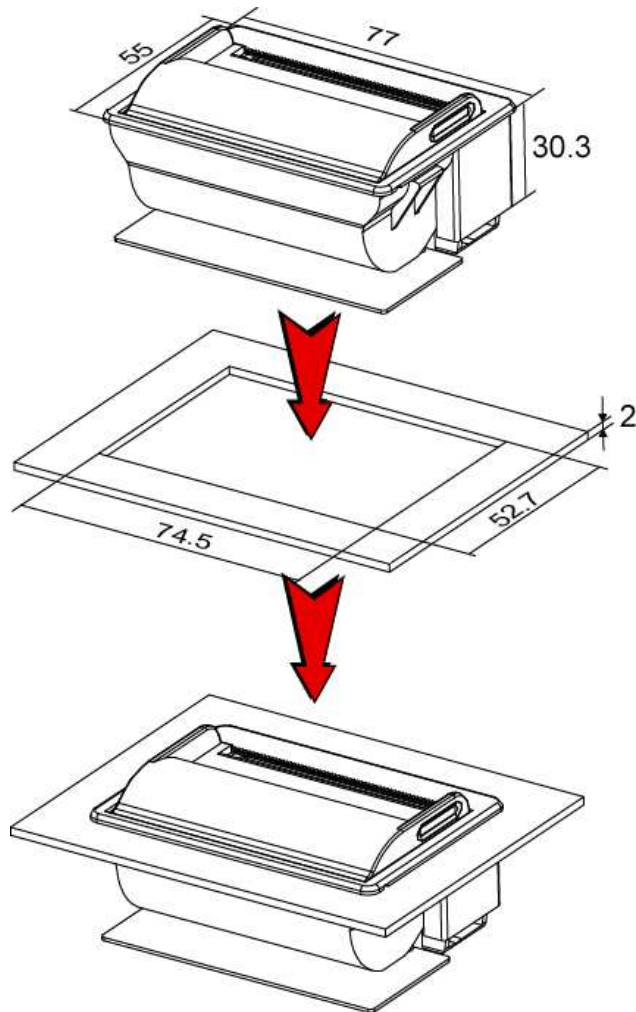

2.3.2. Porti-P40 (include PP40)

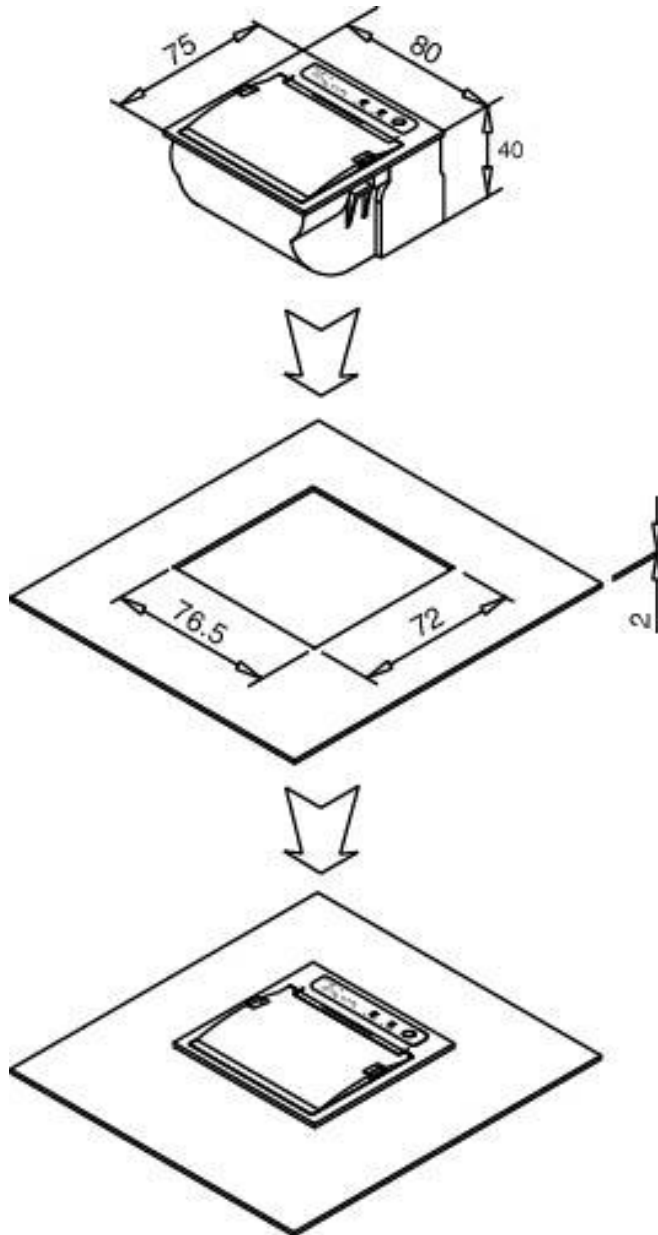

2.3.3. Porti-P240

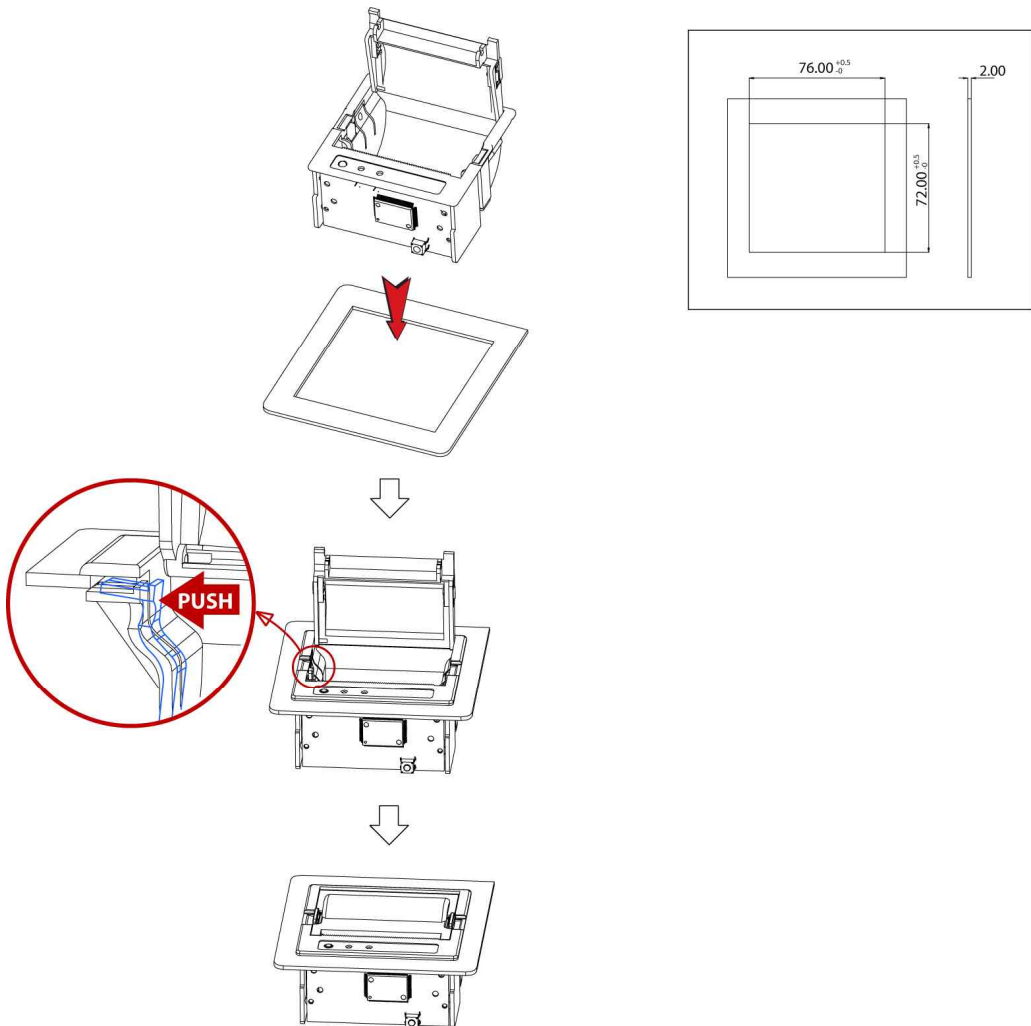

2.3.4. Porti-P60

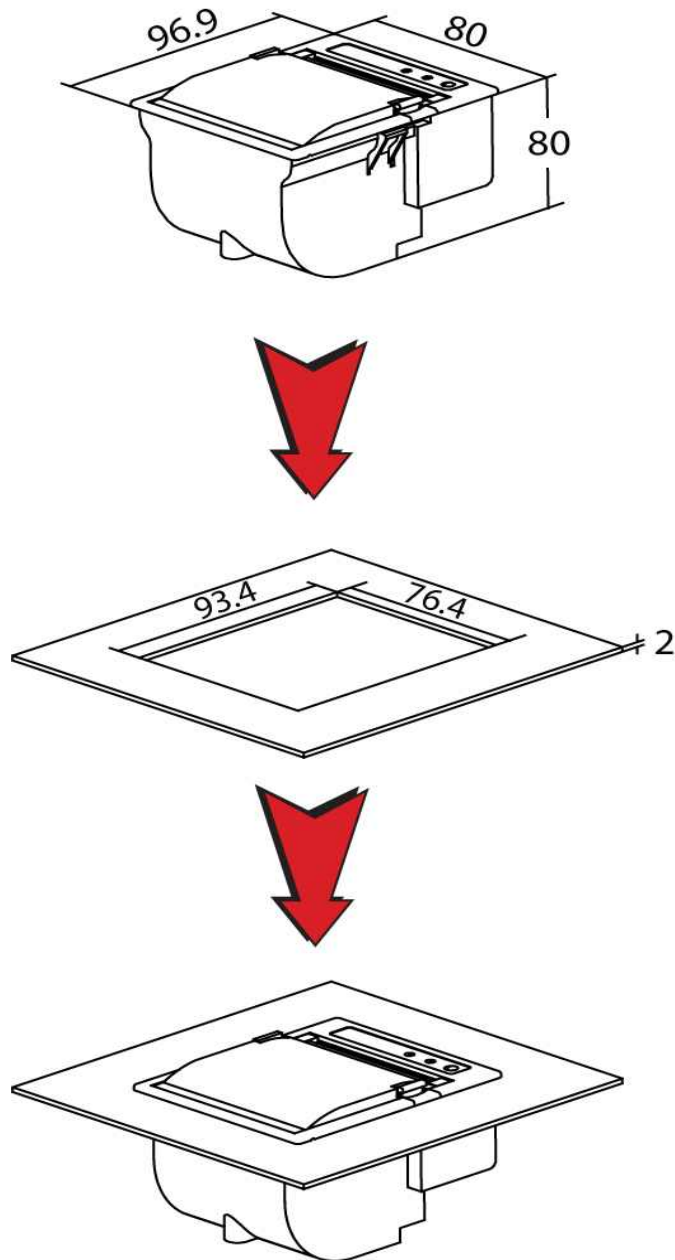

2.4. Replacing the paper roll

Note : Be sure to use paper rolls that meet the specifications.

Do not use paper rolls that have the paper glued to the core because the printer can not detect the paper end correctly.

1. Make sure that the printer is not receiving data; otherwise, data may be lost.
2. Open the paper cover using finger on both side of printer, and remove the remaining paper.

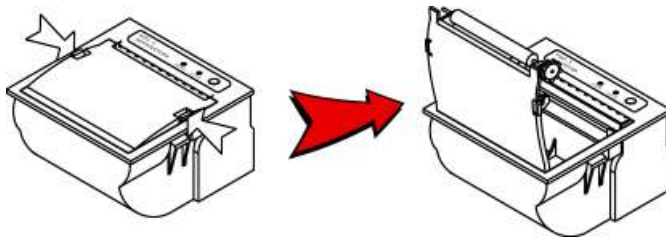

3. Insert the paper roll as shown.

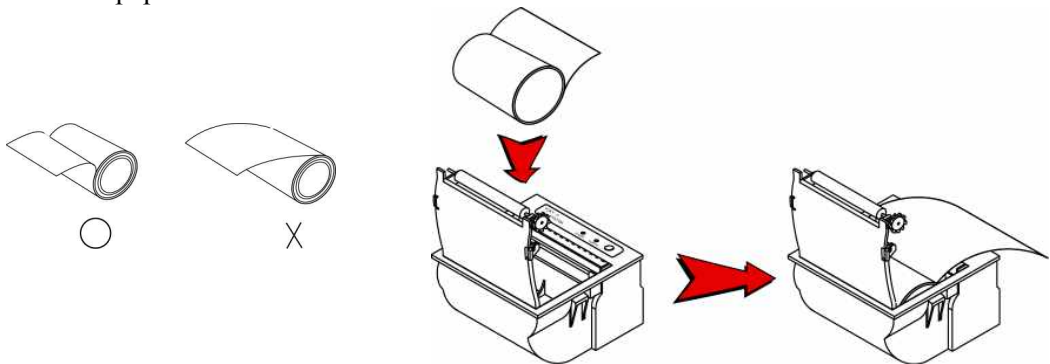

4. Tear the excess paper off using the edge of paper door as a tear bar.

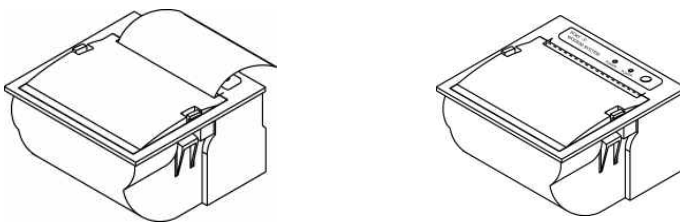

2.5. Setting operation mode

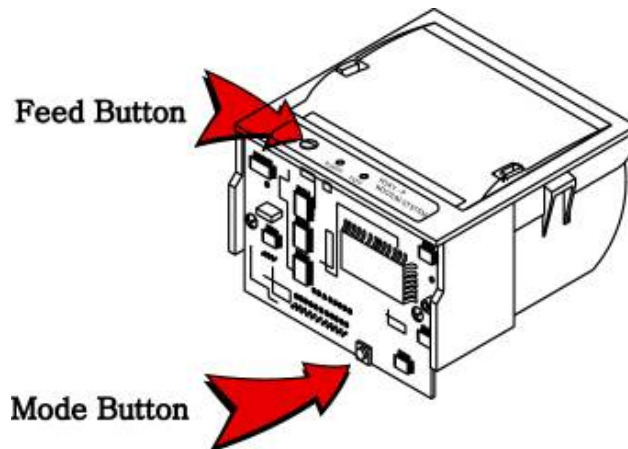

< M37702 (OLD) Version >

Change the mode and option using the MODE Code.

- **MODE button** : use for changing OPTION status. (Error Lamp)
- **FEED button** : use for changing MODE status. (Power Lamp)

[Example] The defaults of the printer are :

RS-232C / 9600 bps / 8 data bit / No parity / Density low / Mark use / Sensor low

If a user wants to modify the defaults with

PARALLEL / 57600 bps / 7 data bit / Odd parity / Density high / Mark no use

/ Sensor Medium1

▶ Press **MODE Button** during the **Error Lamp** flicking 5 times.

→ You will see the **Power Lamp** and the **Error Lamp** flickers once.

→ Press the **MODE Button** twice and the **Error Lamp** flickers 3 times.

And then, interface mode has set to **PARALLEL** mode.

▶ When you press **FEED button** once again, **Power Lamp** flickers twice and the **Error Lamp** flickers 4 times.

→ Press **MODE Button** 3 times, **Error Lamp** flickers 7 times.

And then, baudrate has set to **57,600 bps**.

- ▶ When you press **FEED Button** once again, **Power Lamp** flickers 3 times and the **Error Lamp** flickers twice.
→ Press **MODE Button** once, **Error Lamp** flickers once.
And then Data Bit has set to **7 data bit**.
- ▶ When you press **FEED Button** once again, **Power Lamp** flickers 4 times and the **Error Lamp** flickers once.
→ Press **MODE Button** twice, **Error Lamp** flickers 3 times.
And then the Parity bit has set to **Odd parity bit**.
- ▶ When you press **FEED Button** once again, **Power Lamp** flickers 5 times and **Error Lamp** flickers once.
→ Press **MODE Button** twice, **Error Lamp** flickers 3 times.
And then the density has set to **Density high**.
- ▶ When you press **FEED Button** twice, **Power Lamp** flickers 7 times and **Error Lamp** flickers twice.
→ Press **MODE Button** once, **Error Lamp** flickers twice.
And then the mark has set to **Marm no use**.
- ▶ When you press **FEED Button** once again, **Power Lamp** flickers 8 times and **Error Lamp** flickers once.
→ Press **MODE Button** once, **Error Lamp** flickers twice.
And then the sensor has set to **Sensor medium1**.

If all the mode have set, press the **MODE Button** and the **FEED Button** at the same time after then release the buttons at the same time.

The printer will print out the mode status which has modified.

(**PARALLEL / 57,600 baud / 7 data bit / Odd parity / Density high / Mark no use**
/ **Sensor medium1**)

If the status is not correct, please try it again according to the procedure.

* M37702 (OLD) Version

MODE	POWER Lamp (Green)	ERROR Lamp (Red)	Option
Communication Port	1	1	RS-232C
		2	PARALLEL
		3	PARALLEL
Baud Rate	2	1	1200 bps
		2	2400 bps
		3	4800 bps
		4	9600 bps
		5	19200 bps
		6	38400 bps
		7	57600 bps
		8	115200 bps
Data Bit	3	1	7 Data bit
		2	8 Data bit
Parity Bit	4	1	No Parity
		2	Even Parity
		3	Odd Parity
Density	5	1	Density Low
		2	Density Medium
		3	Density High
Protocol	6	1	Default Protocol
		2	Lotte Protocol
Mark	7	1	No use
		2	Use
Sensor	8	1	Low
		2	Medium1
		3	Medium2
		4	High

< Table 2 >

< M16C, ARM (NEW) Version >

Change the mode and option using the MODE Code.

- **MODE button** : use for changing OPTION status. (Error Lamp)
- **FEED button** : use for changing MODE status. (Power Lamp)

[Example] The defaults of the printer are :

UART / 9600 bps / 8 data bit / No parity / 1 stop bit / Density low
/ Mark use / Sensor low

If a user wants to modify the defaults with

Protocol UART / 57600 bps / 7 data bit / Odd parity / 2 stop bit / Density high
/ Mark no use / Sensor medium1

- ▶ Press **MODE Button** during the **Error Lamp** flicking 5 times.
→ You will see the **Power Lamp** and the **Error Lamp** flickers once.
→ Press the **MODE Button** once and the **Error Lamp** flickers twice.
And then, interface mode has set to **Protocol UART** mode.
- ▶ When you press **FEED button** once again, **Power Lamp** flickers twice and the **Error Lamp** flickers once.
→ Press **MODE Button** 3 times, **Error Lamp** flickers 4 times.
And then, baudrate has set to **57,600 bps**.
- ▶ When you press **FEED Button** once again, **Power Lamp** flickers 3 times and the **Error Lamp** flickers twice.
→ Press **MODE Button** once, **Error Lamp** flickers once.
And then Data Bit has set to **7 data bit**.
- ▶ When you press **FEED Button** once again, **Power Lamp** flickers 4 times and the **Error Lamp** flickers once.
→ Press **MODE Button** once, **Error Lamp** flickers twice.
And then the Parity bit has set to **Odd parity bit**.
- ▶ When you press **FEED Button** once again, **Power Lamp** flickers 5 times and **Error Lamp** flickers once.
→ Press **MODE Button** once, **Error Lamp** flickers twice.
And then the density has set to **2 stop bit**.

- ▶ When you press **FEED Button** once again, **Power Lamp** flickers 6 times and **Error Lamp** flickers once.
→ Press **MODE Button** twice, **Error Lamp** flickers 3 times.
And then the density has set to **Density high**.
- ▶ When you press **FEED Button** once again, **Power Lamp** flickers 7 times and **Error Lamp** flickers twice.
→ Press **MODE Button** once, **Error Lamp** flickers once
And then the mark has set to **Mark no use**.
- ▶ When you press **FEED Button** once again, **Power Lamp** flickers 8 times and **Error Lamp** flickers once.
→ Press **MODE Button** once, **Error Lamp** flickers twice
And then the sensor has set to **Sensor medium1**.

If all the mode have set, press the **MODE Button** and the **FEED Button** at the same time after then release the buttons at the same time.

The printer will print out the mode status which has modified.

**(Protocol UART / 57600 bps / 7 data bit / Odd parity / 2 stop bit / Density high /
Mark no use / Sensor medium1 / Power down no use)**

If the status is not correct, please try it again according to the procedure.

* M16C , ARM (NEW) Version

MODE	POWER Lamp (Green)	ERROR Lamp (Red)	Option
Communication Port	1	1	UART(RS-232C)
		2	Protocol UART(RS-232C)
Baud Rate	2	1	9600 bps
		2	19200 bps
		3	38400 bps
		4	57600 bps
		5	115200 bps
Data Bit	3	1	7 Data bit
		2	8 Data bit
Parity	4	1	No Parity
		2	Odd Parity
		3	Even Parity
Stop bit	5	1	1 stop bit
		2	2 stop bit
Density	6	1	Density Low
		2	Density Medium
		3	Density High
Mark	7	1	No use
		2	Use
Sensor	8	1	Low
		2	Medium1
		3	Medium2
		4	High

< Table 3 >

2.6. Power supply

The following specifications are requested for Power supply.

INPUT POWER:

1. Porti-P30,P40, P240 : DC 5V / Max 2.5A
2. Porti-P30, P40,P240, P60 : DC 9V / Max 3A
3. Porti-PP40,PP60 : DC 12~24V / Max 3A

Avoid using power supply which its power capacity of power current is extremely high.

3. Interface

3.1. Serial Interface (Porti-P30)

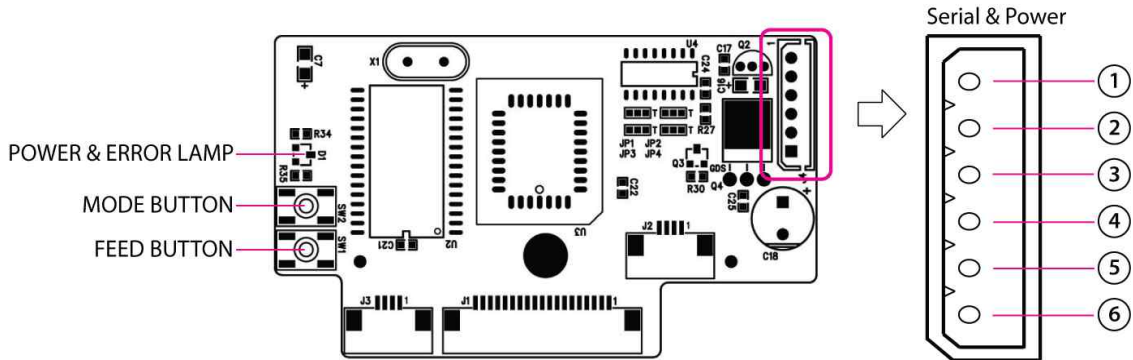

The Porti-P30 printer has a UART(RS-232C or TTL) interface and power connector is connected by 6 pin female connector.

In the following table, the signals present on the connector are listed:

Pin no.	Signal name	Direction	Function
6	INPUT	-	5V/2.5A or 9V/3A
5	TxD	Output	Transmit Data
4	RxD	Input	Receive Data
3	N.C	-	-
2	N.C	-	-
1	GND	-	Ground

<J4 : MOLEX (5267-06P)>

Applicable connector : MOLEX 5264-06P or equivalent.



WARNING

A wrong connection of power supply connector could be damage the printer.

3.2. Serial Interface (Porti-P40 /60, P240)

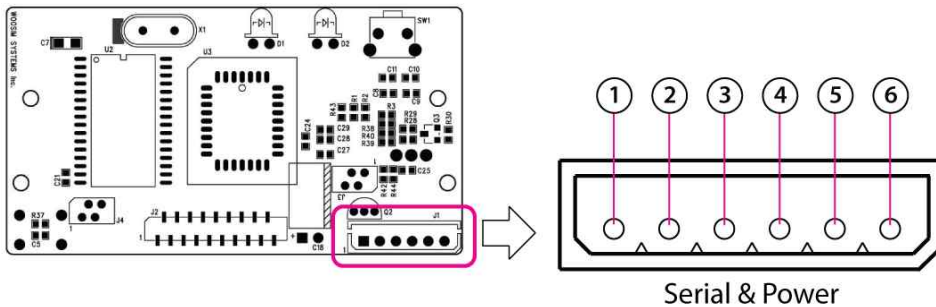

The Porti-P40/P60(P240) printer has a UART (RS-232C or TTL) serial interface and power connector is connected by 6 pin female connector. In the following table, the signals present on the connector are listed:

Pin no.	Signal name	Direction	Function
6	INPUT	-	5V/2.5A or 9V/3A
5	TxD	Output	Transmit Data
4	RxD	Input	Receive Data
3	N.C	-	-
2	N.C	-	-
1	GND	-	Ground

<J1 : MOLEX (5267-06P)>

Applicable connector : MOLEX 5264-06P or equivalent.



WARNING

A wrong connection of power supply connector could be damage the printer.

3.3. Serial and Parallel Interface (Porti-PP40/60)

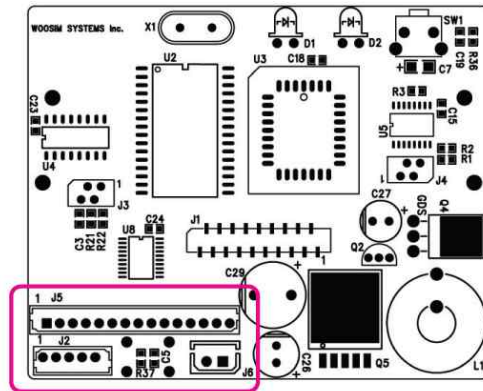

Parallel

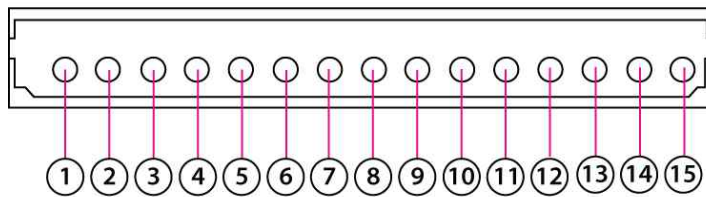

Serial

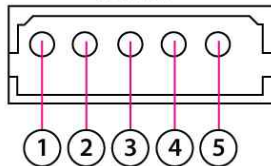

Power

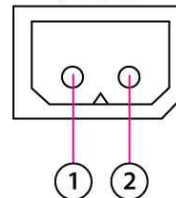

The Porti-PP40/60 printer has Parallel and UART (RS-232C or TTL) interface. They are connected by 5 pin female and 15 pin female connector. In the following table, the signals present on the connector are listed:

- Parallel

PIN No.	Signal	etc
1	STB	
2	DATA BIT 0	
3	DATA BIT 1	
4	DATA BIT 2	
5	DATA BIT 3	
6	DATA BIT 4	
7	DATA BIT 5	
8	DATA BIT 6	
9	DATA BIT 7	
10	ACK	
11	BUSY	
12	P/E	
13	ERR	
14	INIT	
15	GROUND	

<J5 : MOLEX (53014-15P)>

Applicable connector : MOLEX 51004-15P or equivalent.

- Serial

Pin No.	Signal	etc
5	GND	
4	N.C	
3	N.C	
2	RXD	
1	TXD	

<J2 : MOLEX (53014-05P)>

Applicable connector : MOLEX 51004-05P or equivalent.

● Power

Pin #.	Signal	etc
1	GND	
2	Vpp (12V~24V/3A)	

<J6 : MOLEX (5267-02P)>

Applicable connector : MOLEX 5264-02P or equivalent.



WARNING

A wrong connection of power supply connector could be damage the printer.

4. Using the printer

4.1. Control panel



► Button

- **FEED** : When the printer is on, paper can be feed manually by pressing and holding the FEED button for more than one second.

► Panel Lamp

- **POWER(Green)** : Printer is ON and ready to receive data.
- **ERROR (Red)** : Indicates a fault condition or a printer error.
(i.e : no paper, paper cover opened. etc.)

4.2. The self test

The self test procedure will check most of the printer functions. For self test, turn on the power while holding down the FEED Button. The Self-Test checks the following :

- 1) Make sure paper roll has been installed properly.
- 2) The Self-Test prints the current printer status, which provides the control ROM version and the communication method setting.
- 3) After printing the current printer status, Self-Test will print a pattern using the built-in character set.
- 4) The Self-Test automatically ends.

The printer is ready to receive data as soon as it completed the self test.

5. Consumable Parts

5.1. Recommended paper

Type	: Thermal Paper
Paper width	: 57mm
Paper thickness	: $60 \pm 5 \mu\text{m}$
Outer diameter	: $\varnothing 30\text{mm}$ (P40) or $\varnothing 40\text{mm}$ (P40,P240,PP40) or $\varnothing 60\text{mm}$ (P60,PP60)
Recording side	: Outside of roll



Cautions

1. Do not paste the paper to the core. And the roll paper which has near end mark printing on its near end is recommended.
2. Chemicals or oil may change the color of paper, or printed characters may fade.
3. Change of paper color starts from approx . 70°C .
Pay attention to heat, humidity and sun light.
4. Color of paper may be changed by being scratched by nail or hard metal, etc.

5.2 Printing position

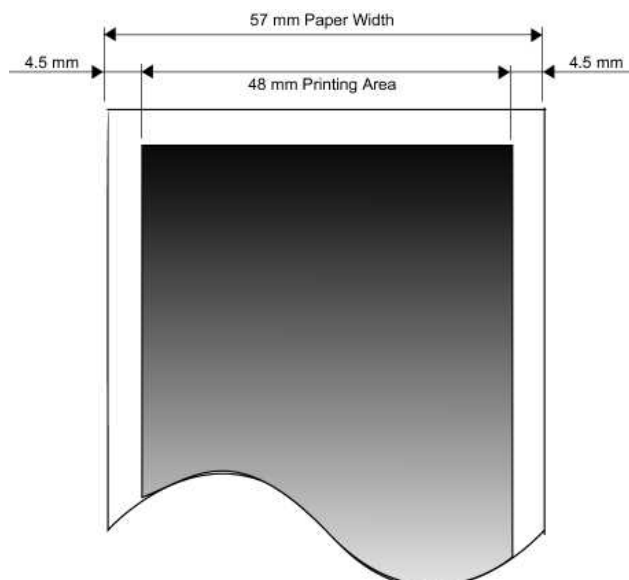

6. Revision History

Date	Version	Comments
May. 21. 2012	5.0	p30 : Parallel pin spec. modify