

MODEL **PORTI-AP60**
(2inch Panel Printer)
Rev. 3.0

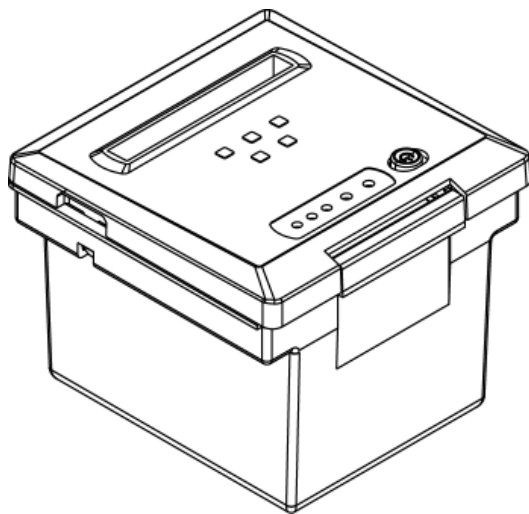

WOOSIM SYSTEMS Inc.
#501, Daerung Technotown 3th, 448,
Gasam-Dong, GeumChun-Ku, Seoul,
Korea
Tel : +82-2-2107-3700
Fax : +82-2-2107-3707
URL: <http://www.woosim.com>

All specifications are subjected to change without notice

! Copyright

PORTI-AP60 2inch Panel Printer Operator's Manual.

Copyright ©2010 by Woosim Systems Inc.

All rights reserved.

The information contained in this manual is the property of Woosim Systems Inc. and may not be reproduced in whole or in part without the prior written permission of Woosim Systems Inc.

! Trademark



a registered trademark of Woosim Systems Inc.

All other trademark are the properties of their respective companies.

! Caution

Some semiconductor devices are easily damaged by static electricity. You should turn the printer "OFF", before you connect or removed the cable on the rear side, in order to guard the printer against the static electricity.

If the printer is damaged by the static electricity, you should turn the printer "OFF"

! Notice

The contents of this manual are subject to change without notice.

| Introduction

The **Porti-AP60** is the ideal solution for taxi receipt printer, receipt printer, Medical analyzer, industrial instrument, recorder, geological analyzer, underground analyzer, chemical analyzer, metallic analyzer, etc.

The general features of Porti-AP60 printer are as follows:

- U Ultra small size rack mount printer.
- U Very silent printing thru direct thermal printing method.
- U High speed(50mm/sec, MAX)
- U High resolution(203dpi : 8dots/mm).
- U UART(RS-232C), RS-485, Parallel interface
- U Intuitive LED's indicate Power(on/off),Error status
- U Support text and graphic printing.
- U Easier paper roll loading by CLAMSHELL design.
- U Auto cutting.
- U Easier maintenance with self-diagnostics.
- U In field programming – Update Firmware, Download Fonts and Logos
- U Microsoft Windows XP / VISTA / 7 / CE / Linux / Android compatible.
- U Flow control : Software (XON/XOFF)
Hardware flow control not supported in printer.
- U Agency Approvals



! Operating Precautions

Please follow the precautions below to enjoy and maintain the full performance of the printer.

U Using the Printer

- Be careful not to drop or bump the printer on a hard surface.
- Do not install the printer in direct sunlight or such areas.

Suitable environment for the use of the printer is as follows:

Operating temperature :-10°C to 50°C

Relative humidity : 10% to 90% (No condensation)

- Do not install the printer near devices that generate strong electromagnetic fields such as a copy machine.
- Do not open the platen cover during printing .
- Do not remove or reinstall the communication cable during printing or transmission.
- Do not touch the connectors of the communication during printing.
- Switch the POWER OFF when not in use.
- Do not use alcohol or other solvent.

U Thermal Paper Handling

- Store the thermal paper in a cool, dry and dark place.
- Do not rub the paper with hard object.
- Do not leave the paper with hard object.
- Do not allow plastic film, erasers, or adhesive tape to touch the paper for long periods.
- Do not stack the thermal paper with diazo copies immediately after copying or wet-type copies.
- Do not use chemical glue.
- Always use the clean thermal paper.

| Note

This equipment has been tested and found to comply with the limits for a Class B digital device, pursuant to Part 15 the FCC Rules.

These limits are designed to provide reasonable protection against harmful interference in a residential installation.

This equipment generates, uses and can radiate radio frequency energy and, if not installed and used in accordance with the instructions, may cause harmful interference to radio communications.

However, there is no guarantee that interference will not occur in a particular installation.

If this equipment does cause harmful interference to radio or television reception, which can be determined by turning the equipment off and on, the user is encouraged to try to correct the interference by one or more of the following measures:

- Reorient or relocate the receiving antenna.
- Increase the separation between the equipment and receiver.
- Connect the equipment into an outlet on a circuit different from that to which the receiver is connected.
- Consult the dealer or an experienced radio/TV technician for help.

CONTENTS

1. Outline	7
1.1. Model classifications	7
1.2. Product Part Number System	7
1.3. Specifications	8
2. Setting up the printer	9
2.1. Printer & Accessories	9
2.2. Printer Features.....	10
2.2.1. Part name	10
2.2.2. Dimensions	11
2.2.3. Installation.....	12
2.3. Replacing paper roll	13
2.4. Specified power supply	14
3. Interface.....	15
3.1. 9V version : UART(RS-232C) or RS-485.....	15
3.2. 12 or 24V version : UART(RS-232C) and Parallel	16
3.3. Set Operation Mode.....	18
4. Using the printer	19
4.1. Control panel	19
4.2. The self test	19
5. Consumable Parts.....	20
5.1. Recommended paper	20
5.2. Printing position	20

1. Outline

1.1. Model classifications

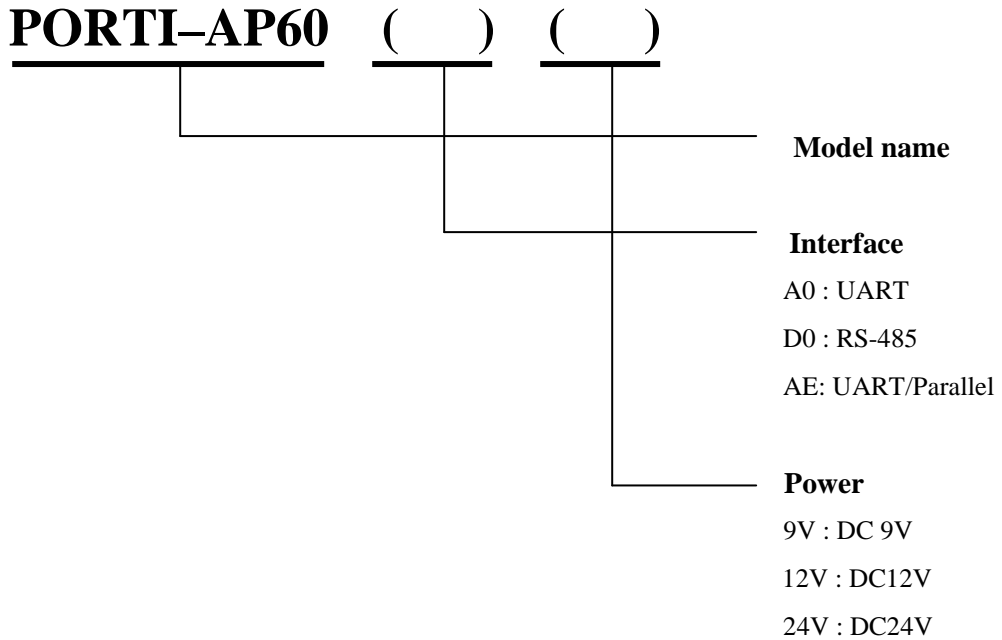

1.2. Product Part Number System

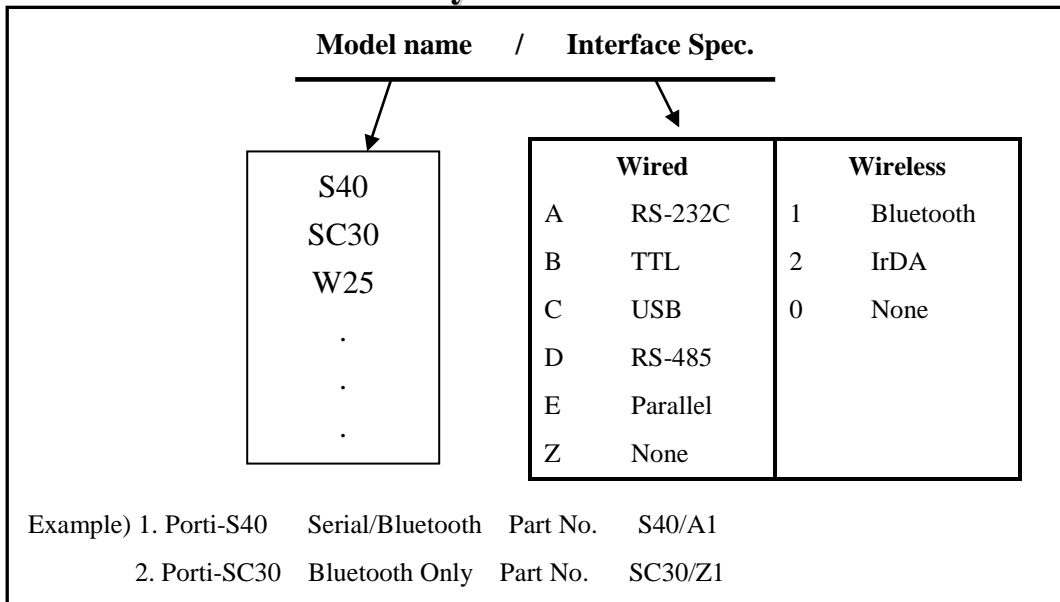

1.3. Specifications

Item	Specification	
Printing method	Direct thermal line printing	
Characters per line	42cpl (MAX)	
Character size	Eng. :9*24dots, 12*24dots Kor. : 16*24dots, [24*24dots]	
Optional Characters	Simplified/Traditional Chinese, Arabic, Cyrillic, Russian, Turkish, Greek, Japanese, Persian, Latin9 and Others upon request.	
Resolution	203dpi, 8dots/mm	
Print width	2-inch (48mm, 384dots)	
Printing speed	50mm / sec (MAX)	
Dimensions	107.2 * 109.1 * 90.6 mm	
Weight	451g (including roll paper)	
Interface	UART(RS-232C), RS-485, Parallel	
Paper supplied	Thermal roll paper (57mm wide, 60ø)	
Barcode supplied	1-dimension : Code128, Code39, I2/5, Code93 UPC, EAN, KAN, JAN, CODABAR 2-dimension : PDF417, QR Code, DATA Matrix	
Driver	Microsoft Widows XP / VISTA / 7 Windows CE, Linux, Android OS driver compatible	
H/W Spec	MCU : 32bits RISC, FLASH : 4Mbytes, RAM : 8Mbytes	
Receive buffer size	1M bytes	
Input Power	9VDC, Stand by 80mA and Max 3A [Cutter Type : 5V] 12VDC, Stand by 80mA and Max 3A [Cutter Type : 5V] 24VDC, Stand by 80mA and Max 3A [Cutter Type : 24V]	
Environment conditions	Temperature	-10°C ~ 50°C (operating) -10°C ~ 70°C (storage)
	Humidity	30% - 80% (operating) 10% - 90% (storage)
MCBF (Mean Cycle Between failure)	Mechanical	37,000,000 lines
	Head	Approximately 50 Km

< Table1 1 >

2. Setting up the printer

2.1. Printer & Accessories

Your printer box should include these items. If any items are damaged or missing, please contact your dealer for assistance.

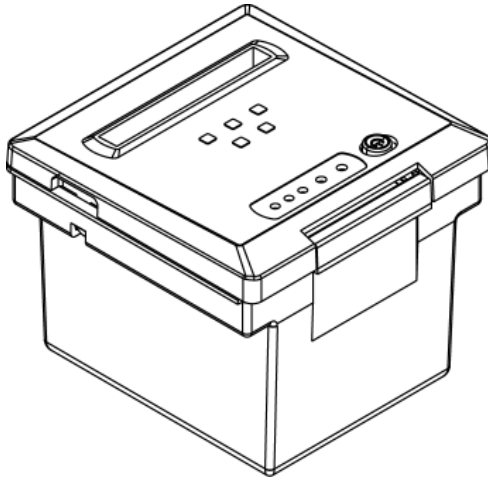

PORTI-AP60

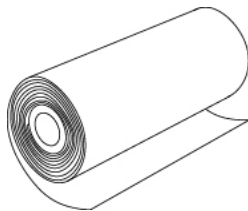

Thermal Roll Paper

2.2. Printer Features

2.2.1. Part name

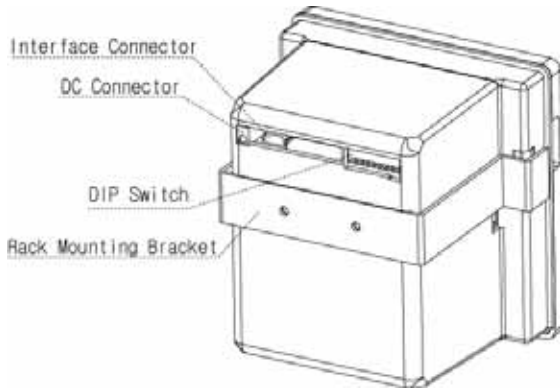
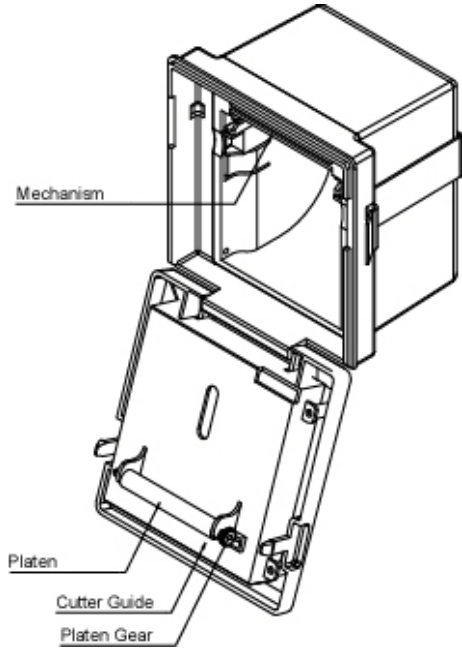
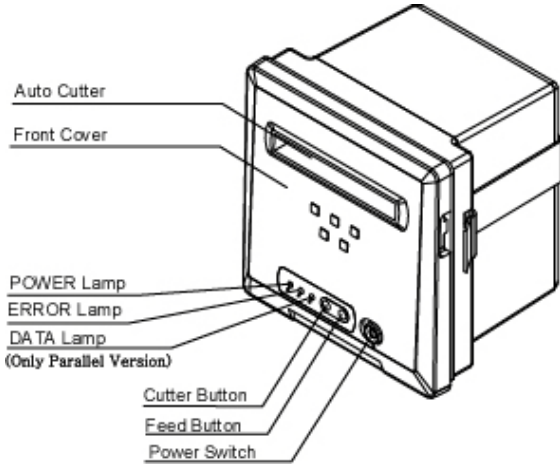

9V Version

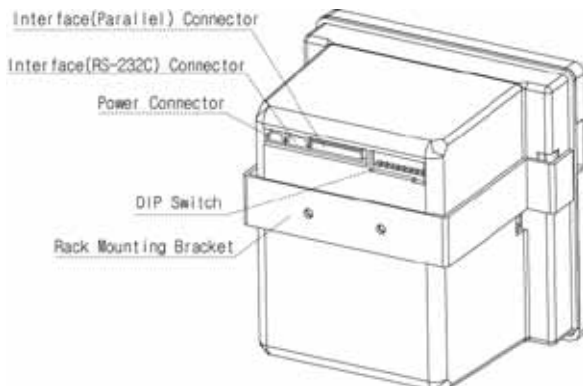

12V or
24V Version

2.2.2. Dimensions

Plate Hole Outline

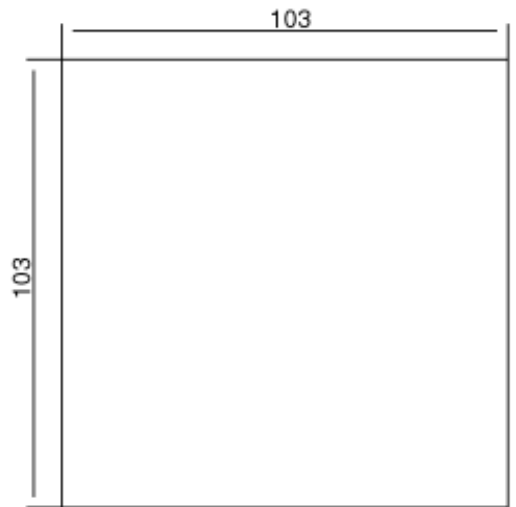
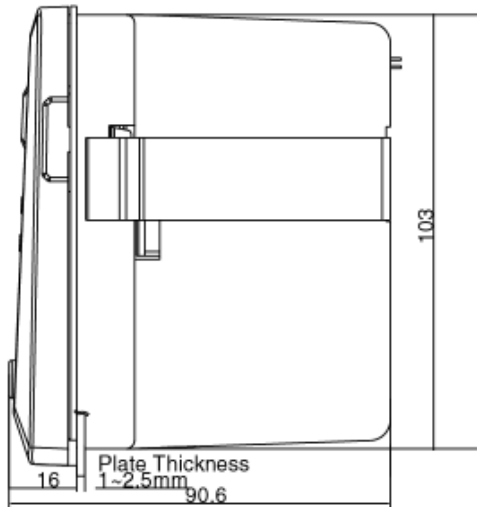
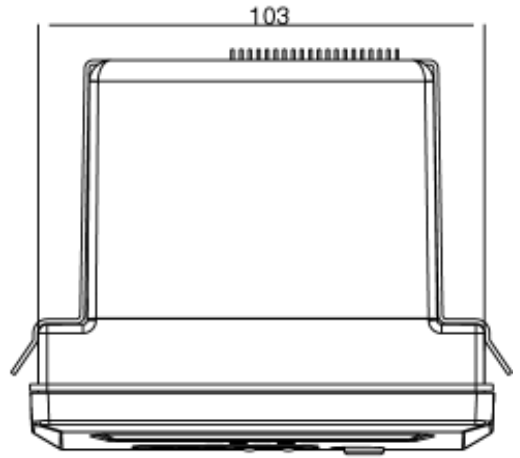
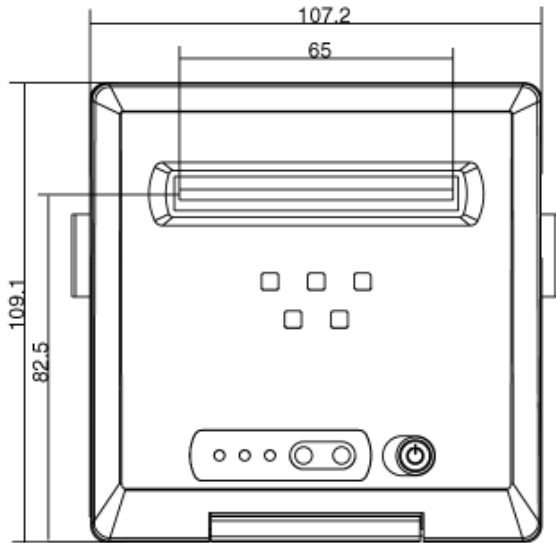
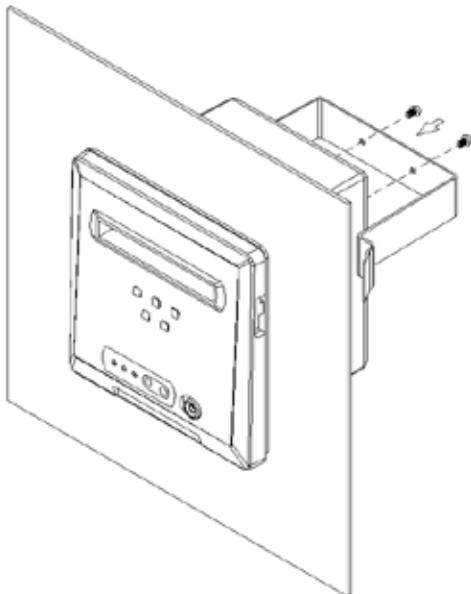
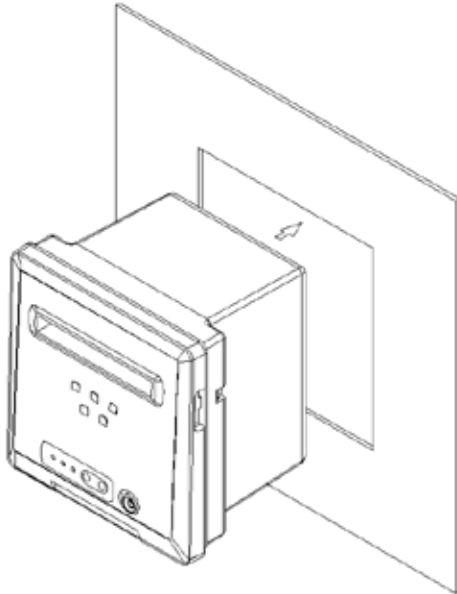

Plate Hole Outline

2.2.3. Installation



- 1) Put the main body into the rack as shown in the following drawing.
- 2) Hold the main body from rear side with mounting bracket, fasten the screws to fix the main body.
- 3) After mounting, make sure that front cover open/close properly
- 4) In fasten screws, do not fasten the screws until the main body is deformed.
This may be abnormal force onto the main body as well as well as be an cause of breakage.
- 5) Thickness of rack panel to fix the main body is to be approx. 1~3 mm.

2.3. Replacing paper roll

Note : Be sure to use paper rolls that meet the specifications.

Do not use paper rolls that have the paper glued to the core because the printer cannot detect the paper end correctly.

1. Make sure that the printer is not receiving data; otherwise, data may be lost.
2. Open the paper roll cover by applying your finger on both side of printer, push it up when the lock is released as shown in the drawing.

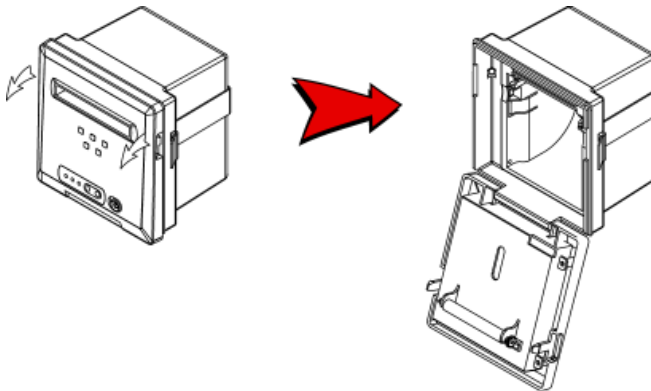

3. Remove the used paper roll core if there is one.
4. Insert the paper roll as shown.

(Be sure to note the correct direction that the paper comes off the roll)

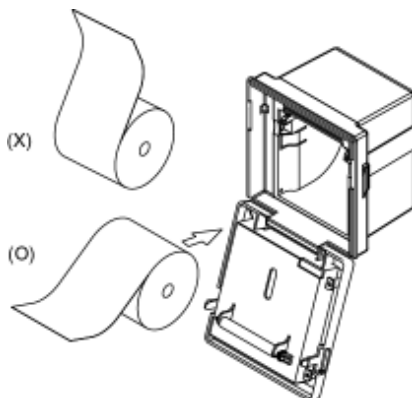

5. Tear the excess paper off using the edge of paper door as a tear bar.

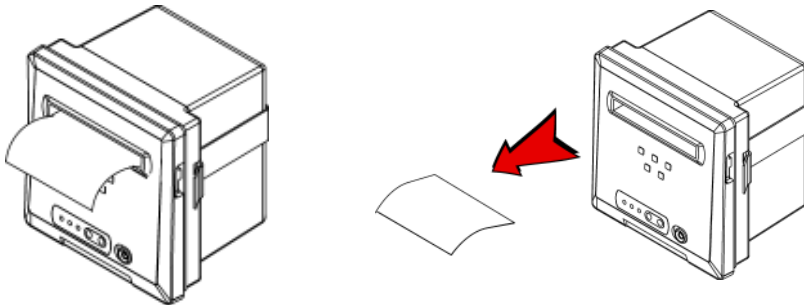

2.4. Specified power supply

The following specifications are requested for Power supply.

INPUT : DC 9V, MAX 3A

DC 12V, MAX 3A

DC 24V, MAX 3A

Avoid using power supply which its power capacity of power current is extremely high.

3. Interface

3.1. 9V version : UART(RS-232C) or RS-485

The Porti-AP60 printer has UART(RS-232C) or RS-485 interface is connected by means of a 3 pin female connector. In the following table, the signals present on the connector are listed:

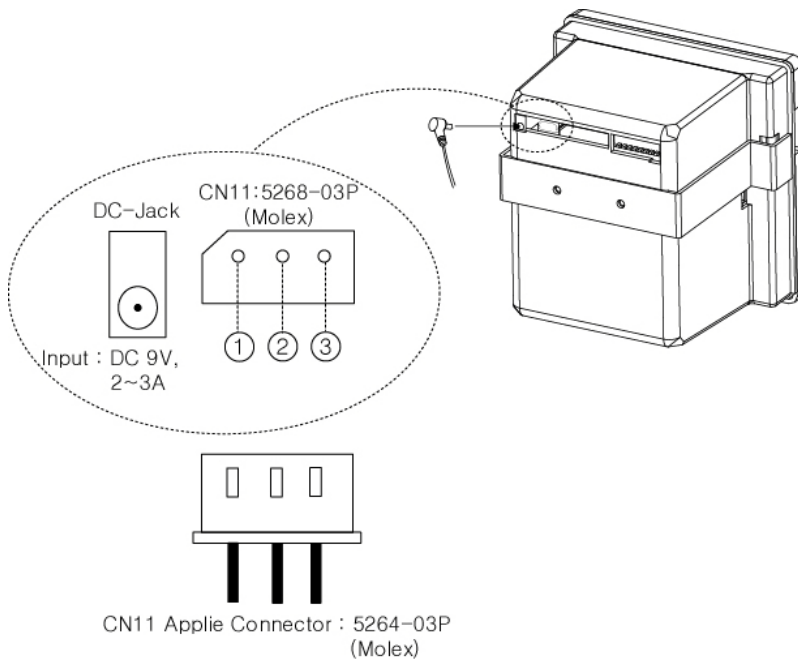

<CN11 : Serial Pin Description>

Pin No.	Signal Name	Direction	Function
1	GND		Ground
2	RxD	Input	Receive Data
3	TxD	Output	Transmit Data

3.2. 12 or 24V version : UART(RS-232C) and Parallel

The Porti-AP60 printer has a UART(RS232C) and Parallel interfaces and is connected by means of a 15 pin male connector. In the following table, the signals present on the connector are listed:

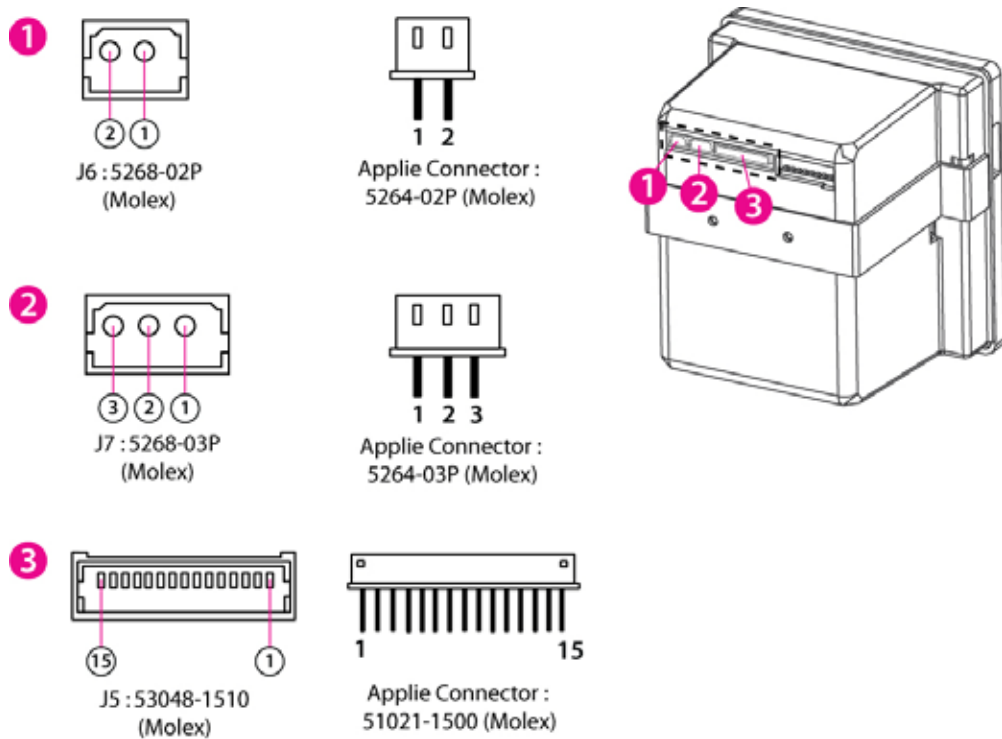

POWER<J6>

Pin NO	Name	Description
2	INPUT	DC12 or 24V/3A
1	GND	Ground

SERIAL<J7>

Pin No.	Name	Direction	Description
3	GND	-	Ground
2	RXD	Input	Receive Data
1	TXD	Output	Transmit Data

PARALLEL<J5>

Pin No.	Name	Direction	Description
15	STB	Output	STROBE
14	D0	"	DATA BIT 0
13	D1	"	DATA BIT 1
12	D2	"	DATA BIT 2
11	D3	"	DATA BIT 3
10	D4	"	DATA BIT 4
9	D5	"	DATA BIT 5
8	D6	"	DATA BIT 6
7	D7	"	DATA BIT 7
6	ACK	Input	Acknowledge
5	BUSY	"	BUSY
4	P/E	"	P.END
3	ERR	"	ERROR
2	INIT	Output	Initialize Printer
1	GND	-	Ground

3.3. Set Operation Mode

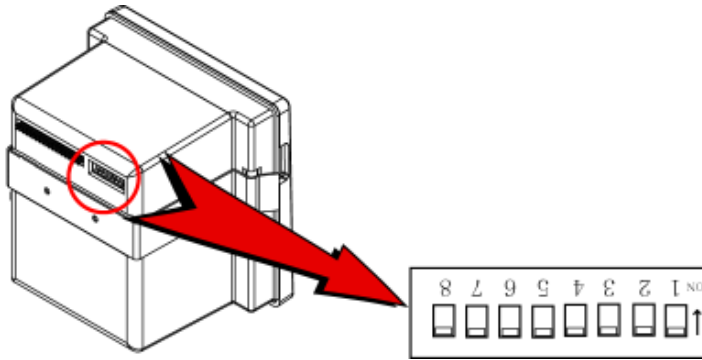

No	DIP SWITCH			No.
1	1	2		
	Off	Off		Density High
	Off	On		Density Medium
	On	Off		Density High
2	3	4	5	
	Off	Off	Off	115200 Baud Rate
	On	Off	Off	57600 Baud Rate
	Off	On	Off	38400 Baud Rate
	On	On	Off	19200 Baud Rate
	Off	Off	On	9600 Baud Rate
	On	Off	On	4800 Baud Rate
	Off	On	On	2400 Baud Rate
3	6			
	Off			PROTOCOL RS232
	On			RS232C
4	7	8		
	Off	Off		Odd Parity, 1 Stop Bit
	Off	On		Even Parity, 1 Stop Bit
	On	Off		Odd Parity, 1 Stop Bit
	On	On		No Parity, 1 Stop Bit

<DIP SWITCH SPECIFICATION>

4. Using the printer

4.1. Control panel

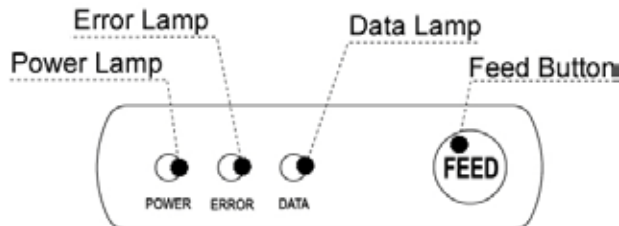

□ Button

- FEED :

When the printer is on, paper can be feed manually by pressing and holding the FEED button for more than one second.

□ Panel Lamp

- **POWER** : Printer is ON and ready to receive data.

- **ERROR** : Indicates a fault condition or a printer error.
(i.e : no paper, paper cover opened. etc.)

- **DATA** : The **DATA** lamp is on whenever the printer receives data.

4.2. The self test

The self test procedure will check most of the printer functions. For self test, turn on the power while holding down the FEED Button. The Self-Test checks the following :

- 1) Make sure paper roll has been installed properly.
- 2) The Self-Test prints the current printer status, which provides the control ROM version and the communication method setting.
- 3) After printing the current printer status, Self-Test will print a pattern using the built-in character set.
- 4) The Self-Test automatically ends.

The printer is ready to receive data as soon as it completed the self test.

5. Consumable Parts

5.1. Recommended paper

Type	: Thermal Paper
Paper width	: 57mm
Paper thickness	: $60 \pm 5 \mu\text{m}$
Outer diameter	: $\text{Ø}60\text{mm}$ or less
Recording side	: Outside of roll



Cautions

1. Do not paste the paper to the core. And the roll paper which has near end mark printing on its near end is recommended.
2. Chemicals or oil may change the color of paper, or printed characters may fade.
3. Change of paper color starts from approx. 70°C .
Pay attention to heat, humidity and sun light.
4. Color of paper may be changed by being scratched by nail or hard metal, etc.

5.2. Printing position

