

Operator's Manual

MODEL

WSP-P440

(4inch Panel Printer)

Rev 4.2

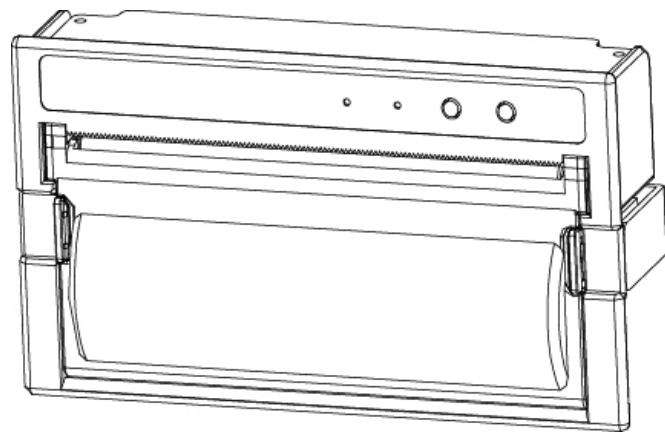

All specifications are subjected to change without notice

■ Copyright

WSP-P440 4inch Panel Printer Operator's Manual.

Copyright ©2021 by Woosim Systems Inc.

All rights reserved.

The information contained in this manual is the property of Woosim Systems Inc.

And may not be reproduced in whole or in part without the prior written permission of Woosim System Inc.

■ Trademark



a registered trademark of Woosim Systems Inc.

All other trademark are the properties of their respective companies.

■ Caution

Some semiconductor devices are easily damaged by static electricity. You should turn the printer "OFF", before you connect or removed the cable on the rear side, in order to guard the printer against the static electricity.

If the printer is damaged by the static electricity, you should turn the printer "OFF"

■ Notice

The contents of this manual are subject to change without notice.

■ Introduction

The **WSP-P440** is an extremely simple and functional panel printer.

It is the ideal solution for applications which require the immediate printing of data on a paper, whether they be of an industrial, professional or laboratory nature.

Medical analyzer, Industrial instrument, Recorder, Geological analyzer, Underground analyzer, Chemical analyzer, Metallic analyzer, etc.

The general features of **WSP-P440** printer are as follows:

- ▶ Very silent printing thru direct thermal printing method.
- ▶ High speed(40mm/sec, MAX)
- ▶ High resolution(203dpi : 8dots/mm).
- ▶ UART(RS-232C or TTL) interface
- ▶ Support text and graphic printing.
- ▶ Easier paper loading by CLAMSHELL design.
- ▶ Easier maintenance with self-diagnostics.
- ▶ In field programming – Update Firmware, Download Fonts and Logos
- ▶ Microsoft Windows/Windows CE, Linux, Android compatible
- ▶ Flow control : Software (XON/XOFF)
 - ※ Hardware flow control not supported in printer.
- ▶ Agency Approvals



■ Operating Precautions

Please follow the precautions below to enjoy and maintain the full performance of the printer.

▶ Using the Printer

- Be careful not to drop or bump the printer on a hard surface.
- Do not install the printer in direct sunlight or such areas.
Suitable environment for the use of the printer is as follows:
 - ◆ Operating temperature :-10°C to 50°C
 - ◆ Relative humidity : 30% to 85%
- Do not install the printer near devices that generate strong electromagnetic fields such as a copy machine.
- Do not open the platen cover during printing .
- Do not remove or reinstall the communication cable during printing or transmission.
- Do not touch the connectors of the communication during printing.
- Switch the POWER OFF when not in use.
- Do not other solvent.

▶ Thermal Paper Handling

- Store the thermal paper in a cool, dry and dark place.
- Do not rub the paper with hard object.
- Do not leave the paper with hard object.
- Do not allow plastic film, erasers, or adhesive tape to touch the paper for long periods.
- Do not stack the thermal paper with diazo copies immediately after copying or wet-type copies.
- Do not use chemical glue.
- Always use the clean thermal paper.

CONTENTS

- 1. Outline 6**
 - 1.1. Model classifications 6
 - 1.2. Product Part Number System..... 6
 - 1.3. Specifications..... 7
- 2. Setting up the printer..... 8**
 - 2.1. Printer & Accessories 8
 - 2.2. Printer Features 9
 - 2.2.1. Part Name 9
 - 2.2.2. Dimension 9
 - 2.3. Panel Installation..... 10
 - 2.4. Replacing the paper roll..... 11
 - 2.5. Setting operation mode 12
 - 2.6. Power supply 13
- 3. Interface..... 14**
 - 3.1. UART(RS-232C or TTL) 14
- 4. Using the printer..... 15**
 - 4.1. Control panel..... 15
 - 4.2. The self test 15
- 5. Consumable Parts 16**
 - 5.1. Recommended paper..... 16
 - 5.2 Printing position 16
- 6. Revision History 17**

1. Outline

1.1. Model classifications

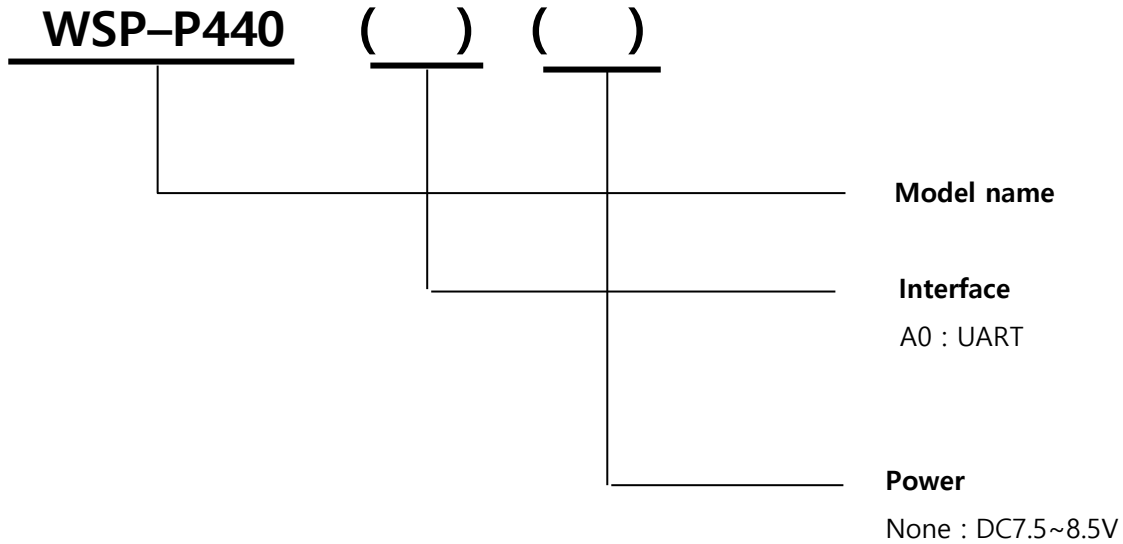

1.2. Product Part Number System

Model name / Interface Spec.

S40

SC30

W25

.

.

.

Wired		Wireless	
A	RS-232C	1	Bluetooth
B	TTL	2	IrDA
C	USB	0	None
D	RS-485		
E	Parallel		
Z	None		

Example) 1. Porti-S40 Serial/Bluetooth Part No. ⇒ S40/A1
 2. Porti-SC30 Bluetooth Only Part No. ⇒ SC30/Z1

Note) The above table is the interface format which is supported.
 But some of the interfaces are not supported according to the product and please contact us, if you have any questions regarding the interface.

1.3. Specifications

Item	Specification	
Printing method	Direct thermal line printing	
Characters per line	- Font A : 69cpl / Font B : 92cpl / Font C : 104cpl - KOR, CHN, JPN : 34cpl	
Character size	- Font Size A: 12X24 / Font Size B : 9X24 / Font Size C : 8X16 - KOR : 24X24(16X24) / CHN, JPN : 24X24	
Optional Characters	Alphanumeric:95, Extended Graphics:128X31 pages, International:10, Simplified/Traditional Chinese, Japanese, Korean	
Resolution	203dpi, 8dots/mm	
Print width	4-inch (104mm, 832dots)	
Printing speed	40mm/sec (MAX)	
Dimensions	143.0 x 77.7 x 49.1mm	
Weight (w/o roll paper)	227g	
Interface	UART(RS-232C or TTL), USB (option)	
Paper supplied	Thermal roll paper (113mm wide - 38ø)	
Barcode supplied	1-dimension : UPC-A, UPC-E, EAN-8, EAN-13, CODE-39, CODE-93, CODE-128, ITF, CODABAR 2-dimension : PDF417, Micro PDF417, Truncated PDF417, QR-CODE, DATA Matrix, Maxicode Etc :GS1 databar	
Driver	Microsoft Windows, Linux	
H/W spec	MCU : RX-32bit, RAM : 128M bit, FLASH : 64M bit	
Receive buffer size	1M bytes	
Input Power	DC7.5~8.5V (MAX 9VDC), Standby 60mA and 3A or more (Please apply the core of the following specifications to the DC Input line for this product.) ** CORE : ZCAT2035-0930 (TDK Corporation)	
Environment conditions	Temperature	-10°C ~50°C (operating) -30°C ~ 70°C (storage)
	Humidity	30% - 80% (operating) 10% - 90% (storage)
MCBF (Mean Cycle Between failure)	Mechanical	37,000,000 lines
	Head	Approximately 50Km

< Table 1 >

2. Setting up the printer

2.1. Printer & Accessories

When unpacking your printer box make sure it contains the printer and all accessories.
If any accessories are missing or damage, please contact your dealer for assistance.

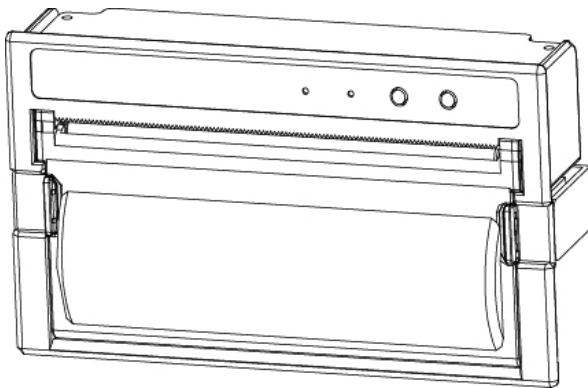

WSP-P440

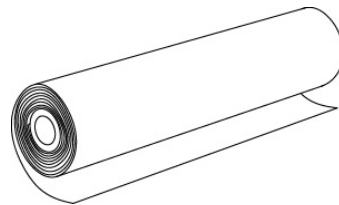

Thermal roll paper

2.2. Printer Features

2.2.1. Part Name

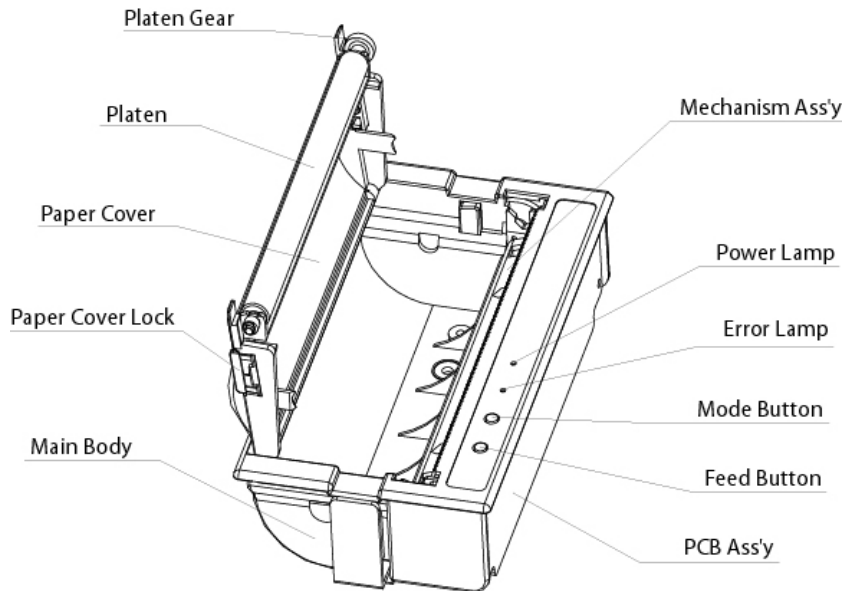

2.2.2. Dimension

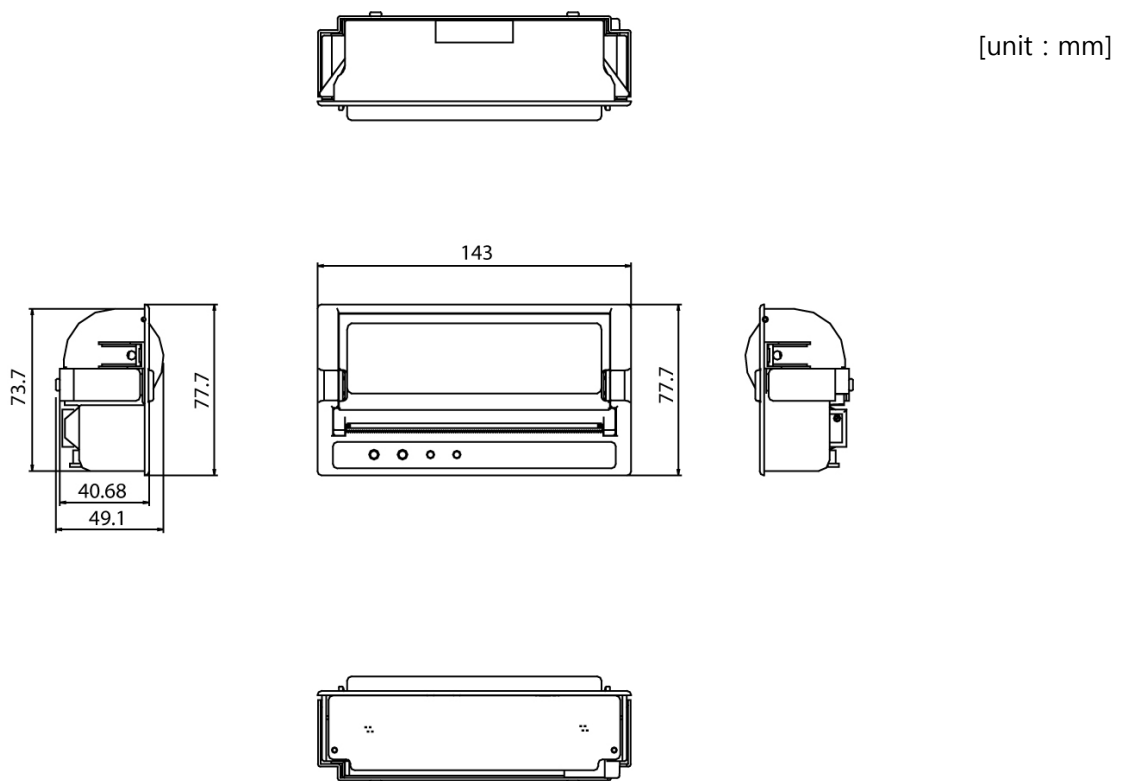

2.3. Panel Installation

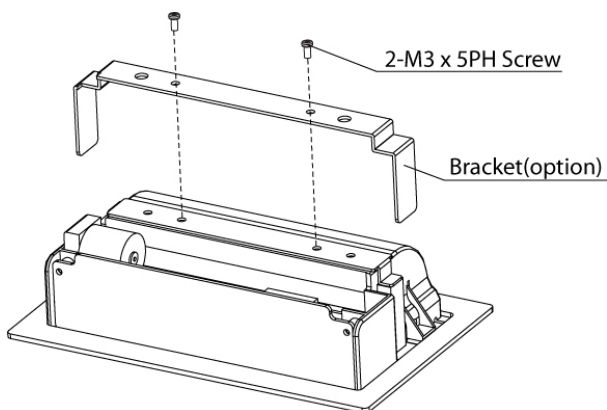
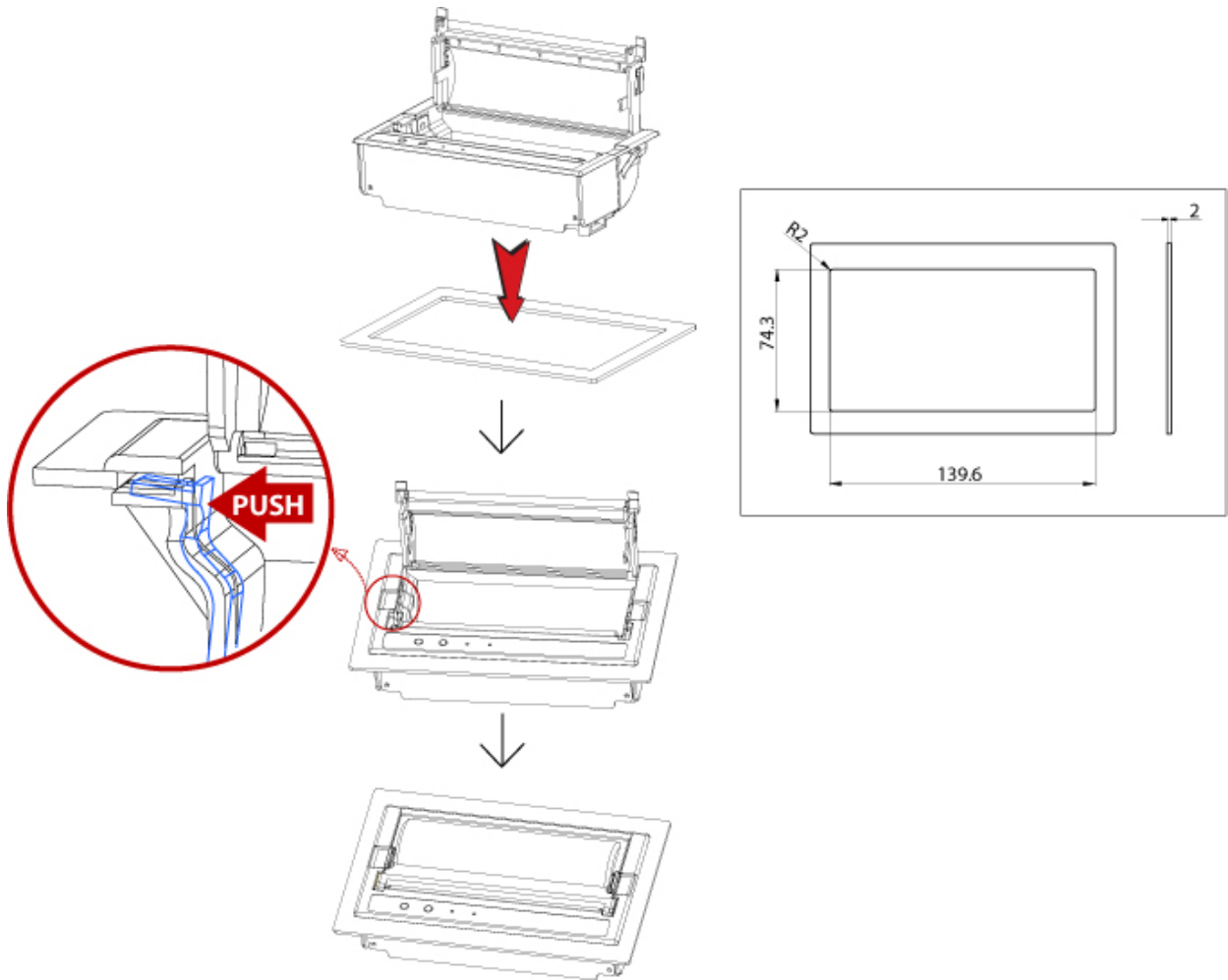

Uses the bracket(option) and the printer once more will be able to fix to the panel.

2.4. Replacing the paper roll

Note : Be sure to use paper rolls that meet the specifications.

Do not use paper rolls that have the paper glued to the core because the printer can not detect the paper end correctly.

1. Make sure that the printer is not receiving data; otherwise, data may be lost.
2. Open the paper cover using finger on both side of printer, and remove the remaining paper.

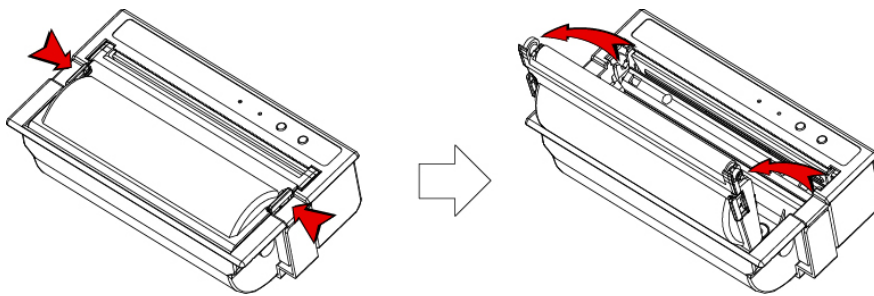

3. Insert the paper roll as shown.

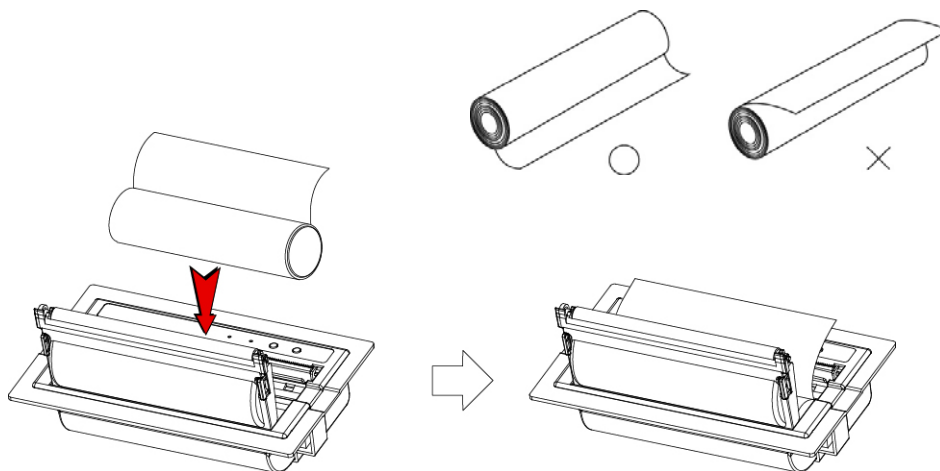

4. Tear the excess paper off using the edge of paper door as a tear bar.

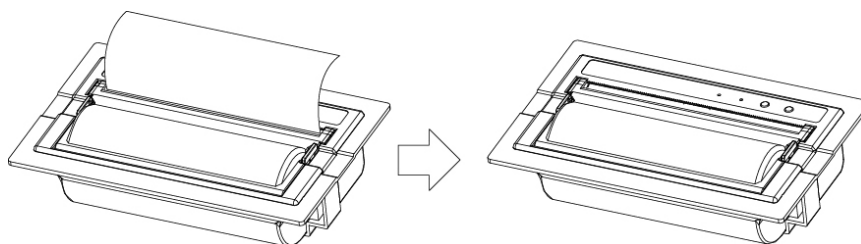

2.5. Setting operation mode

Change the mode and option using the MODE Code.

- **MODE button** : use for changing OPTION status. (Error Lamp)
- **FEED button** : use for changing MODE status. (Power Lamp)

[Example] The defaults of the printer are :

UART / 9600 bps / 8 data bit / No parity / 1 stop bit / Density low

If a user wants to modify the defaults with

Protocol UART / 57600 bps / 7 data bit / Odd parity / 2 stop bit / Density high

- ▶ Press **MODE Button** during the **Error Lamp** flicking 5 times.
 - You will see the **Power Lamp** and the **Error Lamp** flickers once.
 - Press the **MODE Button** once and the **Error Lamp** flickers twice.
 - And then, interface mode has set to **Protocol UART** mode.
 - ▶ When you press **FEED button** once again, **Power Lamp** flickers twice and the **Error Lamp** flickers once.
 - Press **MODE Button** 3 times, **Error Lamp** flickers 4 times.
 - And then, baudrate has set to **57,600 bps**.
 - ▶ When you press **FEED Button** once again, **Power Lamp** flickers 3 times and the **Error Lamp** flickers twice.
 - Press **MODE Button** once, **Error Lamp** flickers once.
 - And then Data Bit has set to **7 data bit**.
 - ▶ When you press **FEED Button** once again, **Power Lamp** flickers 4 times and the **Error Lamp** flickers once.
 - Press **MODE Button** once, **Error Lamp** flickers twice.
 - And then the Parity bit has set to **Odd parity bit**.
 - ▶ When you press **FEED Button** once again, **Power Lamp** flickers 5 times and **Error Lamp** flickers once.
 - Press **MODE Button** once, **Error Lamp** flickers twice.
 - And then the density has set to **2 stop bit**.
 - ▶ When you press **FEED Button** once again, **Power Lamp** flickers 6 times and **Error Lamp** flickers once.
 - Press **MODE Button** twice, **Error Lamp** flickers 3 times.
 - And then the density has set to **Density high**.

If all the mode have set, press the **MODE Button** and the **FEED Button** at the same time after then release the buttons at the same time.

The printer will print out the mode status which has modified.

(Protocol UART / 57600 bps / 7 data bit / Odd parity / 2 stop bit / Density high)

If the status is not correct, please try it again according to the procedure.

MODE	POWER Lamp (Green)	ERROR Lamp (Red)	Option	
Communication Port	1	1	UART	USB
		2	Protocol UART	Protocol USB
Baud Rate	2	1	9600 bps	X
		2	19200 bps	
		3	38400 bps	
		4	57600 bps	
		5	115200 bps	
Data Bit	3	1	7 Data bit	
		2	8 Data bit	
Parity	4	1	No Parity	
		2	Odd Parity	
		3	Even Parity	
Stop bit	5	1	1 stop bit	
		2	2 stop bit	
Density	6	1	Density Low	
		2	Density Medium	
		3	Density High	

< Table 2 >

2.6. Power supply

The following specifications are requested for Power supply.

INPUT POWER: 7.5~8.5VDC / 3A or more

Avoid using power supply which its power capacity of power current is extremely high.

3. Interface

3.1. UART(RS-232C or TTL)

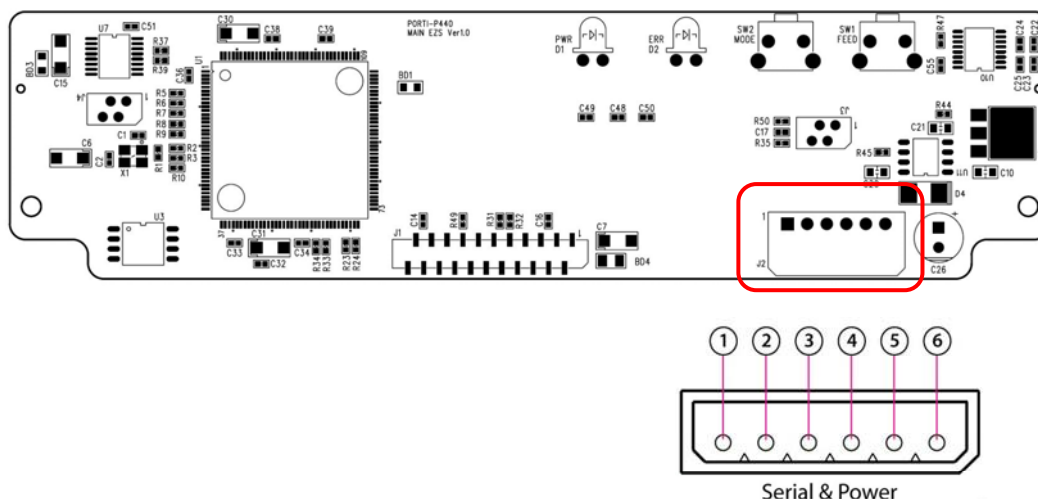

The WSP-P440 printer has a UART(RS-232C or TTL) interface and power connector is connected by 6 pin female connector.

In the following table, the signals present on the connector are listed:

Pin no.	Signal name	Direction	Function
6	INPUT		7.5~8.5VDC / 3A or more
5	TxD	Output	Transmit Data
4	RxD	Input	Receive Data
3	N.C		
2	N.C		
1	GND		Ground

<J2 : MOLEX (5268-06P)>

Applicable connector : MOLEX 5264-06P or equivalent.



WARNING

A wrong connection of power supply connector could be damage the printer.

4. Using the printer

4.1. Control panel



▶ Button

- **FEED** : When the printer is on, paper can be feed manually by pressing and holding the FEED button for more than one second.
- **MODE** : MODE Button is for use to change communication mode.
Do not operate the mode button without instructions.

▶ Panel Lamp

- **POWER(Green)** : Printer is ON and ready to receive data.
- **ERROR (Red)** : Indicates a fault condition or a printer error.
(details : no paper, paper cover opened. etc.)

4.2. The self test

Self-Test prints out the current setting value of printer. The way of self-test is as follows.

1. Insert proper paper into the printer.
2. Power on while pressing feed button to start self-test.
3. Printer will print out the current status. (F/W version and set contents)
4. And then pattern of characters will be printed out.
5. Self-test will be finished automatically and turned to the standby status.

※ In case printer does not work properly, please contact Woosim customer service center.

5. Consumable Parts

5.1. Recommended paper

Type	: Thermal Paper
Paper width	: 113mm
Paper thickness	: $60 \pm 5 \mu\text{m}$
Outer diameter	: $\text{Ø}38\text{mm}$ or less
Recording side	: Outside of roll



Cautions

1. Do not paste the paper to the core. And the roll paper which has near end mark printing on its near end is recommended.
2. Chemicals or oil may change the color of paper, or printed characters may fade.
3. Change of paper color starts from approx. 70°C.
Pay attention to heat, humidity and sun light.
4. Color of paper may be changed by being scratched by nail or hard metal, etc.

5.2 Printing position

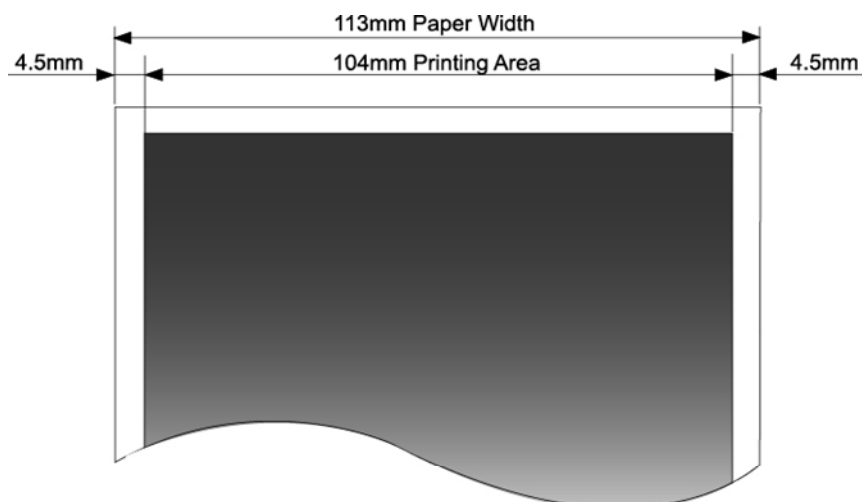

6. Revision History

Date	Version	Comments
Jun. 07. 2017	4.0	RX Version renewal *Change page layout (B5→A4) * Delete address
Sep. 07. 2018	4.1	7,8,14p Input Power modify : 9VDC, Standby 60mA and Max 3A → DC7.5~8.5V (MAX 9VDC) Standby 60mA and 3A or more 15p Serial&Power connector modify 8P → 6P
Oct. 13. 2021	4.2	7p Add Core spec.