

MODEL WSP-BT300

(Kiosk&Ticket Printer)

Rev. 2.0

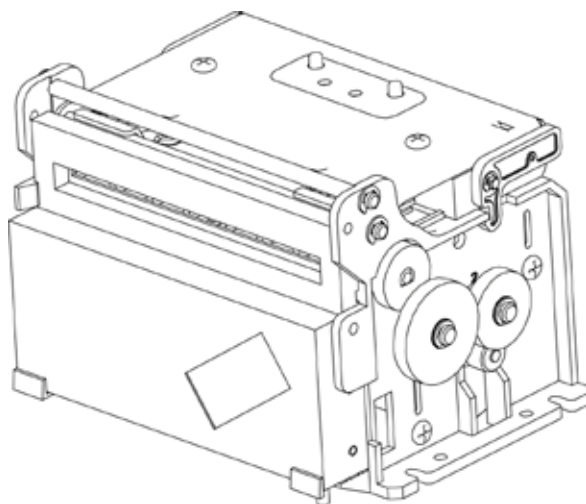

WOOSIM SYSTEMS Inc.

**#501, Daerung Technotown 3th,
448, Gasan-Dong, GeumChun-Ku,
Seoul, Korea**

Tel : +82-2-2107-3700

Fax : +82-2-2107-3707

URL: <http://www.woosim.com>

All specifications are subjected to change without notice

| Copyright

WSP-BT300 Kiosk/Ticket printer operator's manual.

Copyright 2008 by Woosim Systems Inc.

All rights reserved.

The information contained in this manual is the property of Woosim Systems Inc.

and may not be reproduced in whole or in part without the prior written permission of Woosim Systems Inc.

| Trademark



a registered trademark of Woosim Systems Inc.

All other trademark are the properties of their respective companies.

| Caution

Some semiconductor devices are easily damaged by static electricity. You should turn the printer " OFF " , before you connect or removed the cable on the rear side, in order to guard the printer against the static electricity.

If the printer is damaged by the static electricity, you should turn the printer OFF " .

| Notice

The contents of this manual are subject to change without notice.

| Introduction

150mm/sec high-speed printer. The 3inch thermal panel printer is most suitable for ticketing applications, such as transportation, coupons, industrial machine, lottery, ATM and kiosks.

The general features of **WSP-BT300** printer are as follows:

- U Very silent printing thru direct thermal printing method.
- U High speed(150mm/sec, MAX)
- U High resolution(203dpi : 8dots/mm).
- U UART(RS-232C or TTL) Interface
- U Low power consumption.
- U Supports text and graphic printing.
- U Easy paper handing
- U Easier paper roll loading by CLAMSHELL design.
- U Auto cutting.
- U Printer door open & Paper-out sensor
- U Easier maintenance with self-diagnostic.
- U In field programming – Update Firmware, Download Fonts and Logos
- U Microsoft Windows 98 / ME / XP / 2000 / VISTA / 7 compatible.
- U Flow control : Software (XON/XOFF)
Hardware flow control not supported in printer.
- U Agency Approvals



! Operating Precautions

Please follow the precautions below to enjoy and maintain the full performance of the printer.

U Using the Printer

- Be careful not to drop or bump the printer on a hard surface.
- Do not install the printer in direct sunlight or such areas.

Suitable environment for the use of the printer is as follows:

Operating temperature :-10°C to 50°C

Relative humidity : 10% to 90% (No condensation)

- Do not install the printer near devices that generate strong electromagnetic fields such as a copy machine.
- Do not open the platen cover during printing .
- Do not remove or reinstall the communication cable during printing or transmission.
- Do not touch the connectors of the communication during printing.
- Switch the POWER OFF when not in use.
- Do not use alcohol or other solvent.
- The AC adapter, the battery charger and the battery pack may become warm when in use. This is normal and is not a malfunction.
- When the battery pack is used at low temperature, the length of time the printer can be used may be shortened.

U Thermal Paper Handling

- Store the thermal paper in a cool, dry and dark place.
- Do not rub the paper with hard object.
- Do not leave the paper with hard object.
- Do not allow plastic film, erasers, or adhesive tape to touch the paper for long periods.
- Do not stack the thermal paper with diazo copies immediately after copying or wet-type copies.
- Do not use chemical glue.
- Always use the clean thermal paper.

CONTENTS

1. Outline	6
1.1. Model classifications	6
1.2. Product Part Number System.....	6
1.3. Specifications.....	7
2. Setting up the printer	8
2.1. Printer & Accessories	8
2.2. Printer Features	9
2.3. Dimensions	10
2.4. Replacing the paper roll.....	12
2.5. Power Supply.....	13
2.5.1. Power connector	13
2.5.2. Specified Power supply.....	13
2.6. Sensor	14
3. Interface.....	15
3.1. UART(RS-232C or TTL)	15
4. Using the printer	16
4.1. Control panel	16
4.2. The self test.....	17
5. Consumable Parts.....	18
5.1. Recommended paper.....	18
5.2. Printing position.....	18

1. Outline

1.1. Model classifications

WSP-BT300 () ()

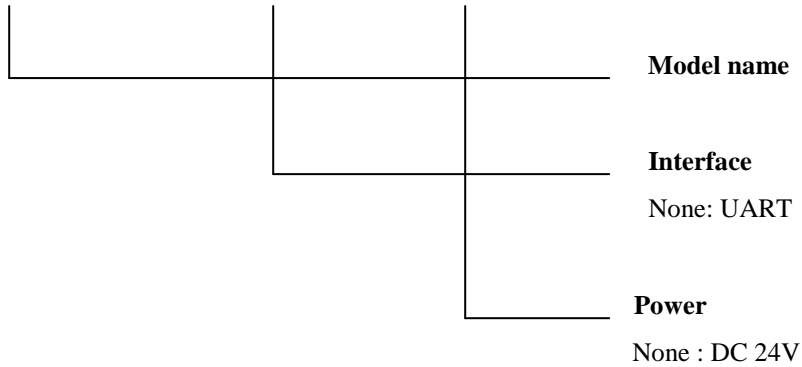

1.2. Product Part Number System

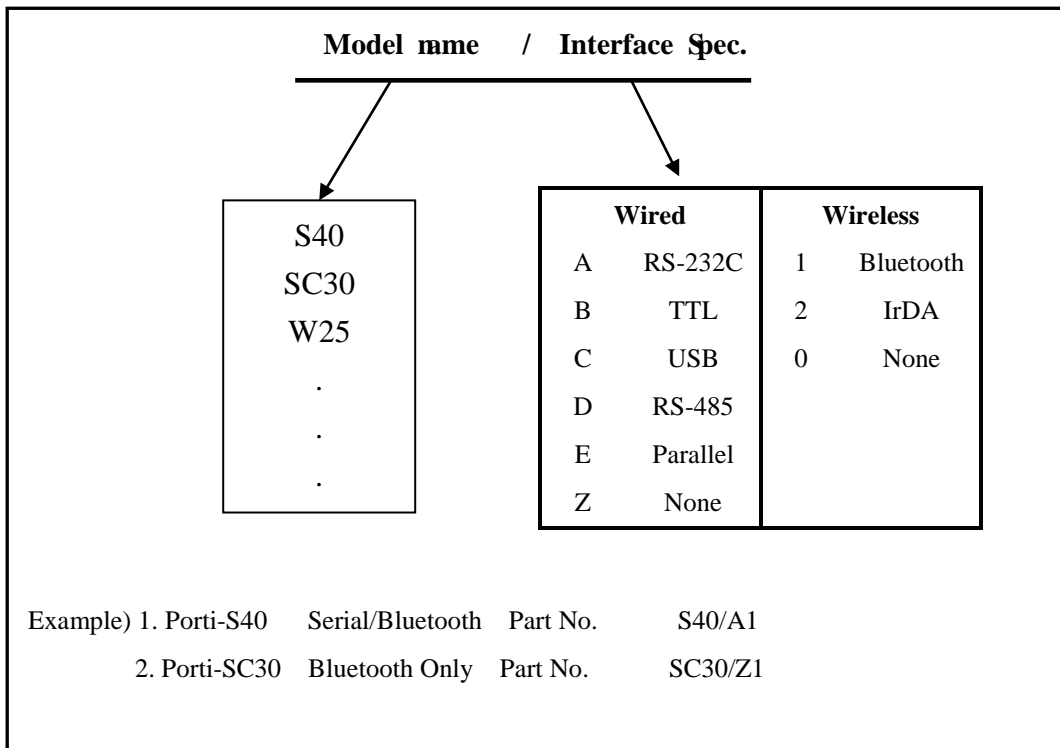

1.3. Specifications

Item	Specification	
Printing method	Direct thermal line printing	
Characters per line	64cpl (MAX)	
Character size	Eng. : 9*24dots, 12*24dots Kor. : 16*24dots, [24*24dots]	
Optional Characters	Simplified/Traditional Chinese, Arabic, Cyrillic, Russian, Turkish, Greek, Japanese, Persian, Latin9 and Others upon request.	
Resolution	203dpi, 8dots/mm	
Print width	3-inch (72mm, 576dots)	
Paper width	80 ± 0.5 mm wide (Thermal roll paper)	
Printing speed	150mm/sec (MAX)	
Dimensions	117 * 87.3 * 112 mm	
Weight	630g (except roll paper)	
Interface	UART (RS-232C or TTL)	
Barcode supplied	1-dimension : Code128, EAN 128, Code39, I2/5, Code93 UPC, EAN, KAN,JAN, CODABAR 2-dimension : PDF417, QR Code, DATA Matrix	
Black mark	Support black mark detection	
H/W Spec.	MCU : 32bits RISC, FLASH : 4M bytes, RAM : 8M bytes	
Receive buffer size	1M bytes	
Input Power	24VDC, Max 3A	
Environment conditions	Temperature	-10°C ~ 50°C (operating) -10°C ~ 70°C (storage)
	Humidity	30% - 80% (operating) 10% - 90% (storage)
MCBF (Mean Cycle Between failure)	Mechanical	37,000,000 lines
	Head	Approximately 100 Km

< Table 1 >

2. Setting up the printer

2.1. Printer & Accessories

When unpacking your printer box make sure it contains the printer and all accessories.
If any accessories are missing or damage, please contact your dealer for assistance.

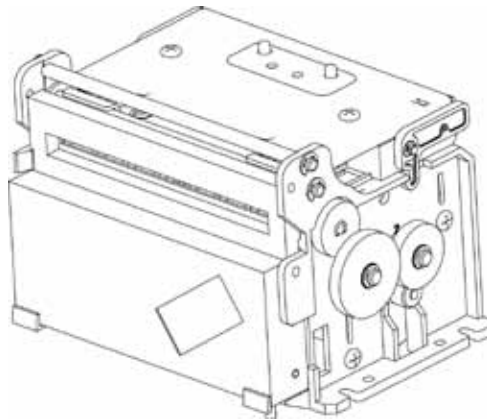

WSP-BT300

2.2. Printer Features

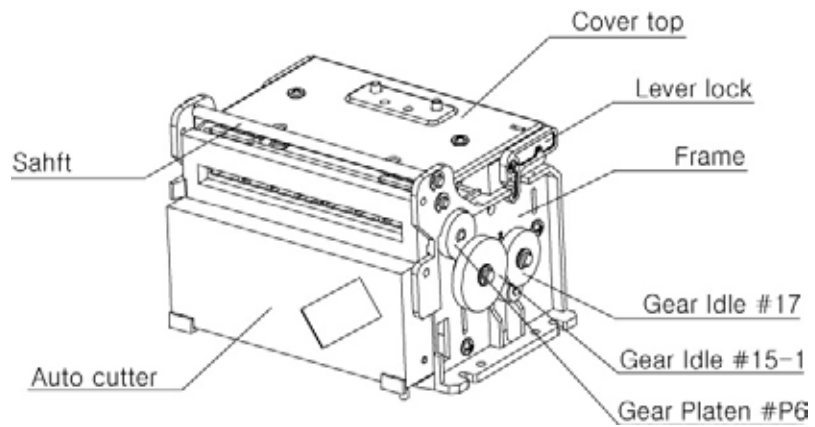
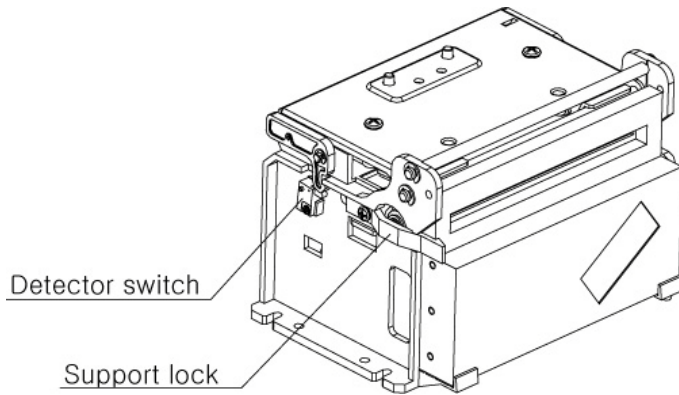

2.3. Dimensions

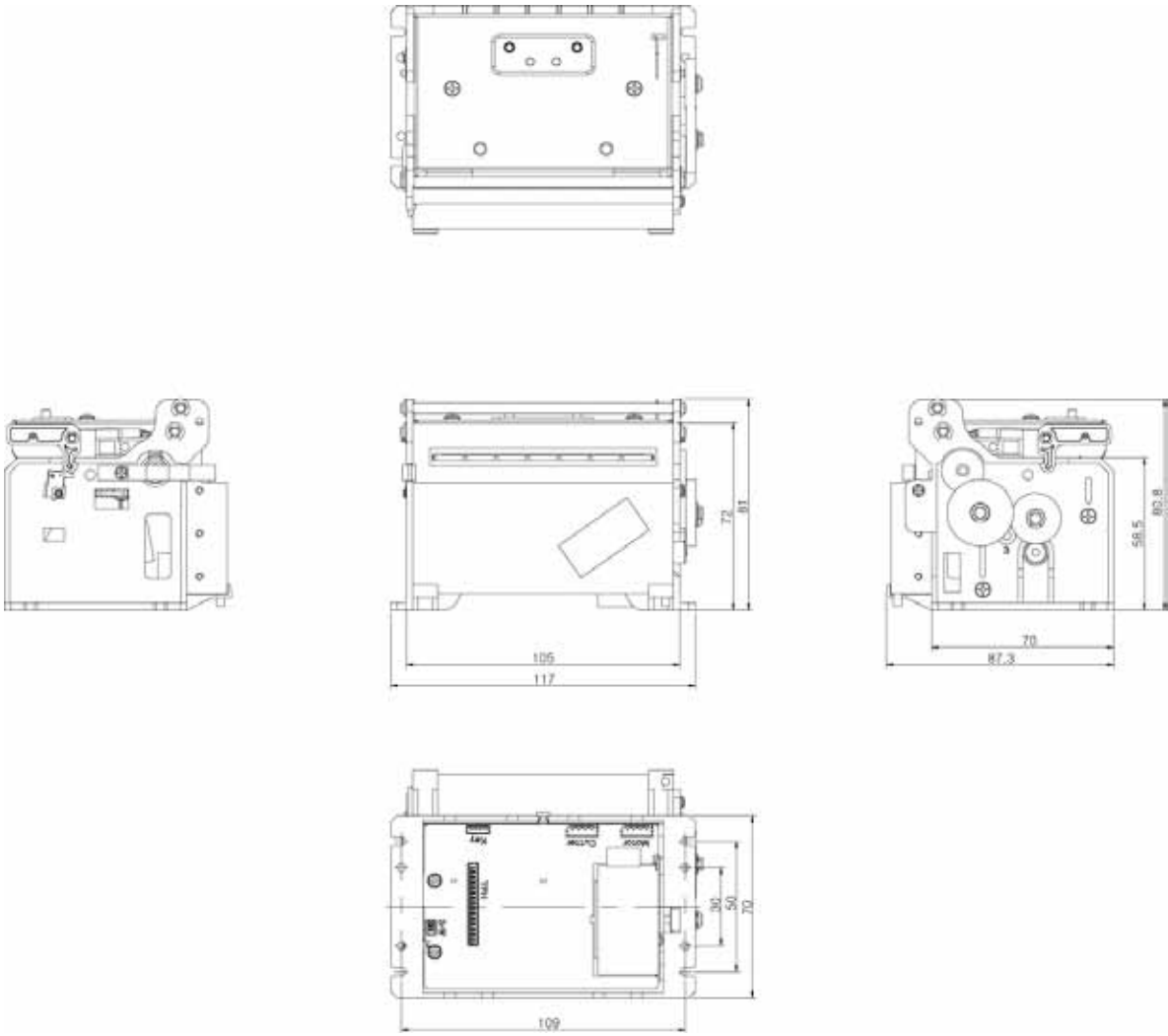

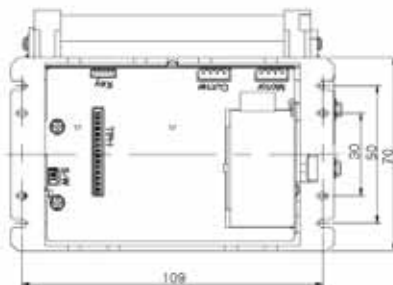
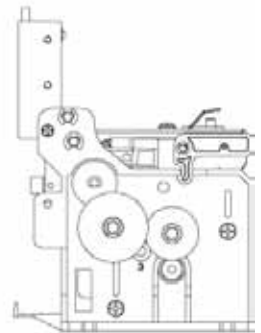
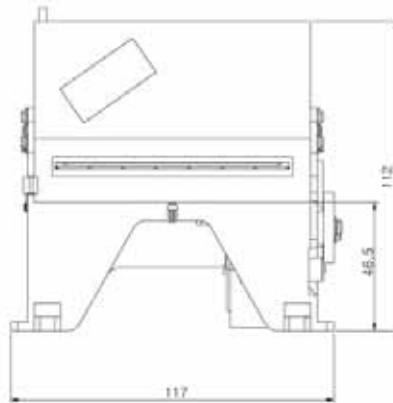
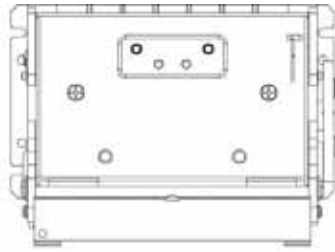

2.4. Replacing the paper roll

Note : Be sure to use paper rolls that meet the specifications.

Do not use paper rolls that have the paper glued to the core because the printer can not detect the paper end correctly.

1. Make sure that the printer is not receiving data; otherwise, data may be lost.
2. Remove the used paper roll core if there is one.
3. Insert the paper roll as shown.

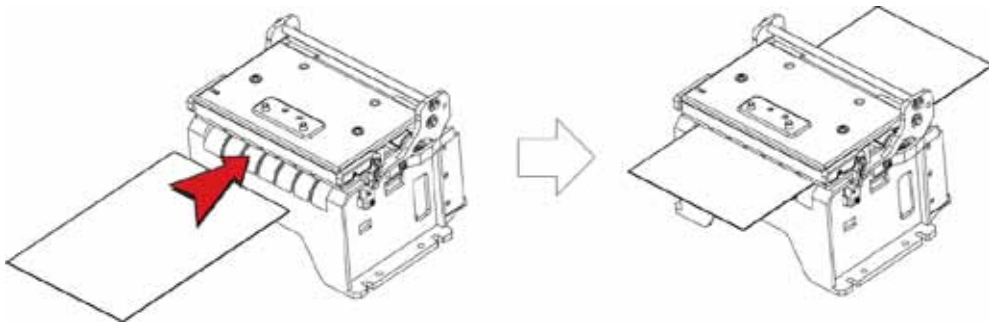

2.5. Power Supply

2.5.1. Power connector

The WSP-BT300 printer is equipped to an external supply electrical power.
The functions assigned to the pins in the connector are as follows:

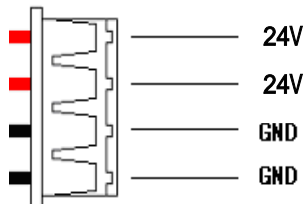

51004-0400 (MOLEX)



WARNING

A wrong connection of power supply connector could be damage the printer.

Applicable connector : MOLEX 53014-0410 or equivalent.

2.5.2. Specified Power supply

The following specifications are requested for Power supply.

Input : 24V DC / MAX 3A

Avoid using power supply which its power capacity of power current is extremely high.

2.6. Sensor

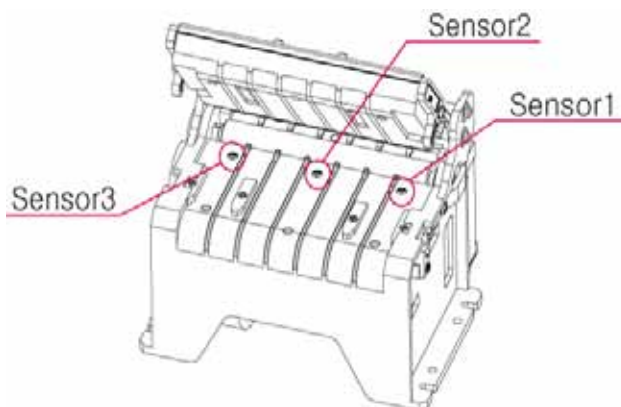
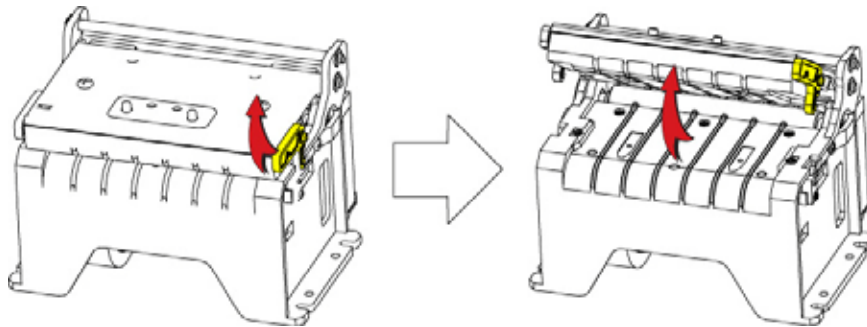

Sensor 1 : Black Mark Sensor

When using label paper etc., is detected with the black mark sensor.

Sensor 2 : Paper Out Sensor

When using the general thermal paper, the sensor which detects the exhaust presence of the paper.

Sensor 3 : Optional Sensor

Currently does not use without being

3. Interface

3.1. UART(RS-232C or TTL)

The WSP-BT300 printer has a UART(RS-232C or TTL) interface and is connected by means of 3 pin female connector. In the following table, the signals present on the connector are listed:

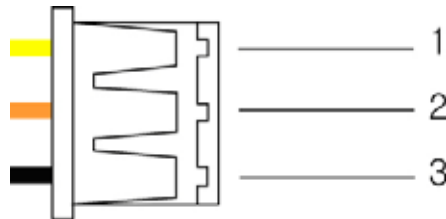

Pin No	Name	Direction	Function
1	TxD	Output	Transmit Data
2	RxD	Input	Receive Data
3	GND	-	Ground

<Molex : 51004-0300 >

Applicable connector : MOLEX 53014-0310 or equivalent.

4. Using the printer

4.1. Control panel

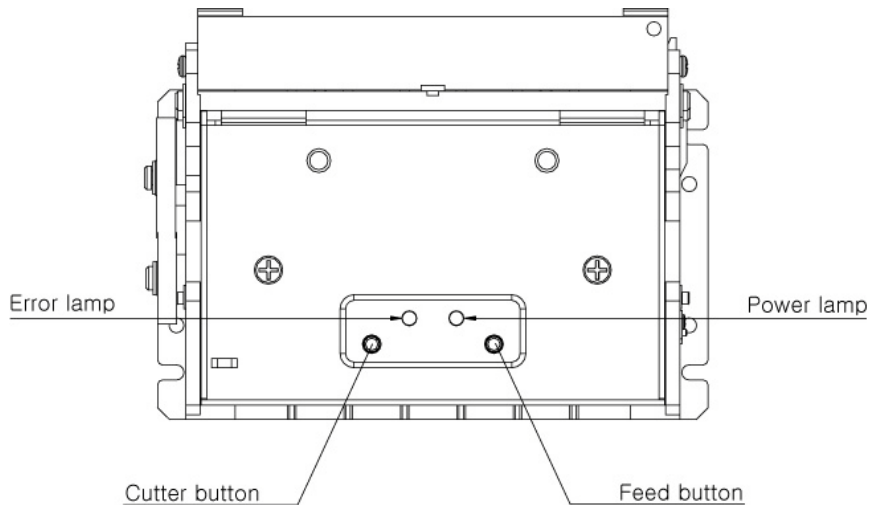

⌋ Button

- FEED Button :

When the printer is on, paper can be feed manually by pressing and holding the FEED button for more than one second.

- CUTTER Button :

Cutter Button is used when once cutting the paper.

⌋ Panel lamp

-**POWER** : Printer is ON and ready to receive data.

-**ERROR** : Indicates a fault condition or a printer error.

(i.e : no paper, etc.)

4.2. The self test

The self test procedure will check most of the printer functions. For self test, turn on the power while holding down the FEED Button. The Self-Test checks the following :

- 1) Make sure paper roll has been installed properly.
- 2) The Self-Test prints the current printer status, which provides the control ROM version and the communication method setting.
- 3) After printing the current printer status, Self-Test will print a pattern using the built-in character set.
- 4) The Self-Test automatically ends.

The printer is ready to receive data as soon as it completed the self test.

5. Consumable Parts

5.1. Recommended paper

Type	: Thermal Paper
Paper width	: 80mm
Paper thickness	: $60 \pm 5 \mu\text{m}$
Recording side	: Outside of roll



Cautions

1. Do not paste the paper to the core. And the roll paper which has near end mark printing on its near end is recommended.
2. Chemicals or oil may change the color of paper, or printed characters may fade.
3. Change of paper color starts from approx. 70°C .
Pay attention to heat, humidity and sun light.
4. Color of paper may be changed by being scratched by nail or hard metal, etc.

5.2. Printing position

